

1

2

3

4

5

6

7

8

A

B

C

D

E

F

G

H

A

B

C

D

E

F

G

H

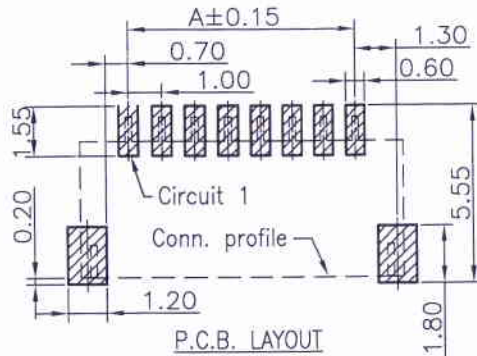

P.C.B. LAYOUT

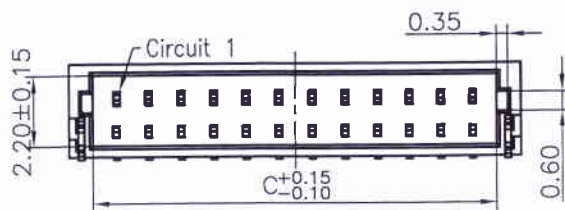
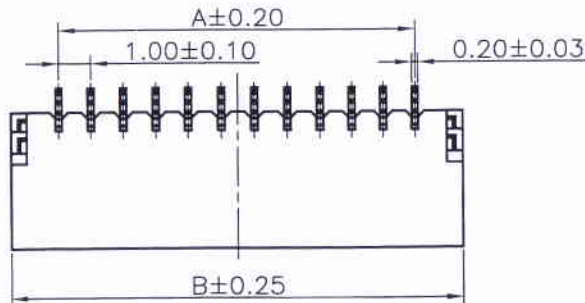

Specifications:

Rated Voltage : 50V AC/DC

Rated Current : 1A AC,DC

Withstand Voltage : 500V AC/minute

Contact Resistance : 20mΩ(MAX.)

Insulation Resistance : 100MΩ(MIN.)

Temperature Range : -25°C~+85°C

The product using material and processing must conform to the "WI-PZ-142" HSF technical standard control requirements

11002W90-NPA-S-XX-HF-R

① ② ③④⑤ ⑥ ⑦ ⑧

① Series No.

② W90 : Side Contact

W00 : Up Contact

③ No. of Circuits

④ A: Product color (A--Y)

Blank : Natural type

⑤ S: SMT type

Blank: DIP type

⑥ 5A : PIN Gold-flash

⑦ HF : Halogen Free

⑧ R : Tape & Reel

Circuits Part No	Dimensions		
	A	B	C
2P	--	4.00	2.50
3P	2.00	5.00	3.50
4P	3.00	6.00	4.50
5P	4.00	7.00	5.50
6P	5.00	8.00	6.50
7P	6.00	9.00	7.50
8P	7.00	10.00	8.50
9P	8.00	11.00	9.50
10P	9.00	12.00	10.50
11P	10.00	13.00	11.50
12P	11.00	14.00	12.50
13P	12.00	15.00	13.50
14P	13.00	16.00	14.50
15P	14.00	17.00	15.50
16P	15.00	18.00	16.50
17P	16.00	19.00	17.50
18P	17.00	20.00	18.50
19P	18.00	21.00	19.50
20P	19.00	22.00	20.50
21P	20.00	23.00	21.50

Part No.	Material	Color	Pin Material	Solder Tabs
11002W90-NP-S-R	High temperature plastic,UL94V-0	Nature (Beige)	Phosphor Bronze/Tin-plated	Phosphor Bronze/Tin-plated
11002W90-NP-S-5A-R	High temperature plastic,UL94V-0	Nature (Beige)	Phosphor Bronze/Gold-flash	Phosphor Bronze/Gold-flash
11002W90-NP-S-HF-R	High temperature plastic,UL94V-0	Nature (Beige)	Phosphor Bronze/Tin-plated	Phosphor Bronze/Tin-plated
11002W90-NPA-S-HF-R	High temperature plastic,UL94V-0	Black	Phosphor Bronze/Tin-plated	Phosphor Bronze/Tin-plated
11002W90-NP-S-5A-HF-R	High temperature plastic,UL94V-0	Nature (Beige)	Phosphor Bronze/Gold-flash	Phosphor Bronze/Gold-flash
11002W90-NPA-S-5A-HF-R	High temperature plastic,UL94V-0	Black	Phosphor Bronze/Gold-flash	Phosphor Bronze/Gold-flash

REV.	REVISION RECORD	DATE	GENERAL TOLERANCES	SCALE:	NAME	DATE	PART. NO:	DWG. NO:	JCTC [®] TERMINAL&CONNECTORS
C3	HN111160148	11.11.16	LINER	1:1			11002W90-NP-S-XX	ENDE05	
C4	WN1309250159	13.09.25	0.0±0.25	APPROVED					
C5	WN1712010179	17.12.01	X° REF±6°	DESIGNER					
C6	更新图框	20.07.01	X° ±3°	DRAWN	伍文聪	20.07.01	TITLE: JST 1.00mm PITCH CONN	REV: C6	
			SIZE: A4					SHEET: 1/2	

1

2

3

4

5

6

7

8

2~13 Contacts

14~21 Contacts

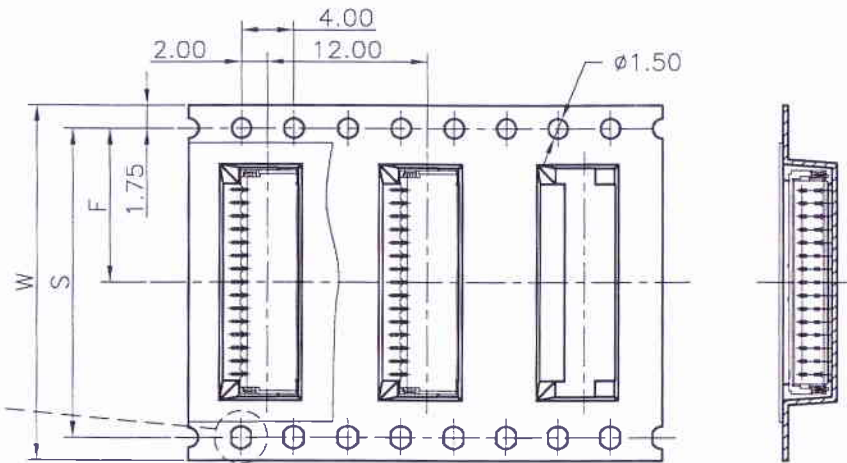
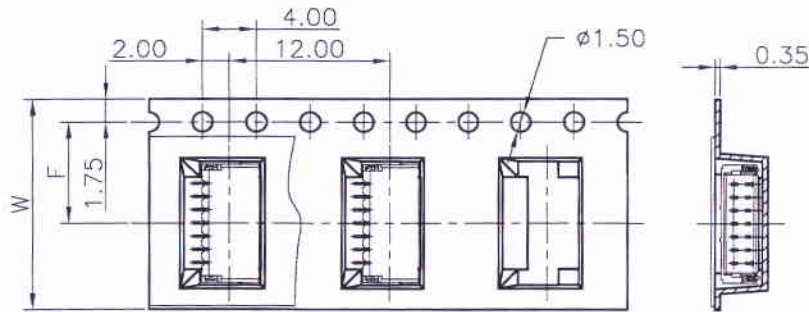

Unreeing direction →

Unreeing direction →

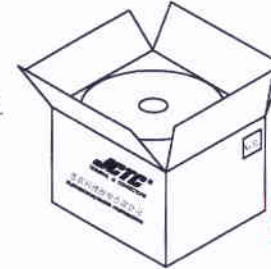
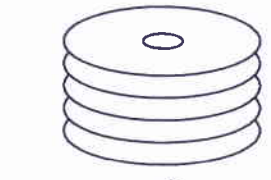
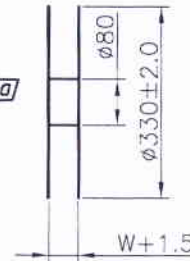
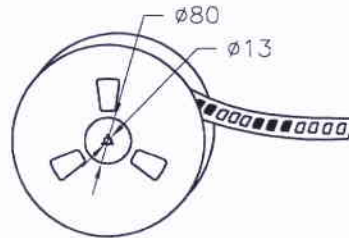
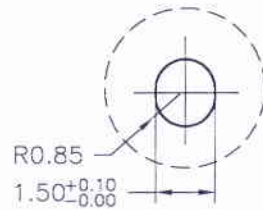
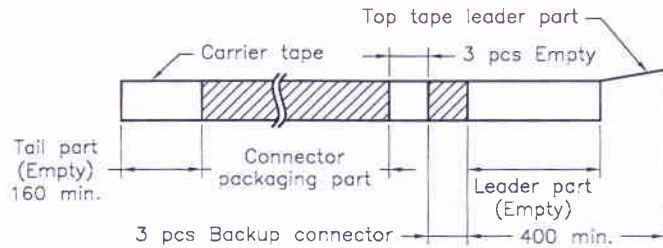

Load carton



Sealed carton

Number of Contacts	W±0.3	F±0.1	S±0.1	Q'ty/Reel	Q'ty/Box
2P-6P	16	7.50	/	1,500	21,000
7P-13P	24	11.50		1,500	15,000
14P-19P	32	14.20	28.40	1,500	12,000
20P-21P	44	20.20	40.40	1,500	9,000

REV.	REVISION RECORD	DATE	GENERAL TOLERANCES		SCALE:	NAME	DATE	PART. NO.	DWG. NO.	 TERMINAL&CONNECTORS
C1	HN1106130090	11.06.13	LINEAR	ANGLES	1:1			11002W90-NP-S-XX	ENDE05	
C2	WN1712010179	17.12.01	0.0±0.25	X° REF±6°	APPROVED	<i>[Signature]</i>	20.07.01	JST 1.00mm PITCH CONN		
C3	WN1908150196	19.08.15	UNIT: MM	0.00±0.15	DESIGNER	<i>[Signature]</i>	20.07.01			
C4	更新图框	20.07.01	SIZE: A4	0.000±0.08	DRAWN	伍文聪	20.07.01			

REV: C4 SHEET: 2/2