

11002W90-NP-SA-H1-XX-HF-R
① ② ③ ④ ⑤ ⑥ ⑦ ⑧ ⑨

- ① Series No.
- ② W90 : Side Contact
W00 : Up Contact
- ③ No. of Circuits
- ④ S : SMT type
- ⑤ A : Mount type
- ⑥ H1: H1 Type
- ⑦ XX : Plated
- ⑧ HF : Halogen Free
- ⑨ R : Reel pack

SPECIFICATIONS

Voltage Rating: 50V AC,DC
 Current Rating: 1A AC,DC
 Withstanding Voltage: 500V AC/minute
 Contact Resistance: 20mΩ Max.
 Insulation Resistance: 100MΩ Min.
 Temperature Range: -25°C ~ +85°C
 The product using material and processing must conform to the "WI-PZ-142" HSF technical standard control requirements

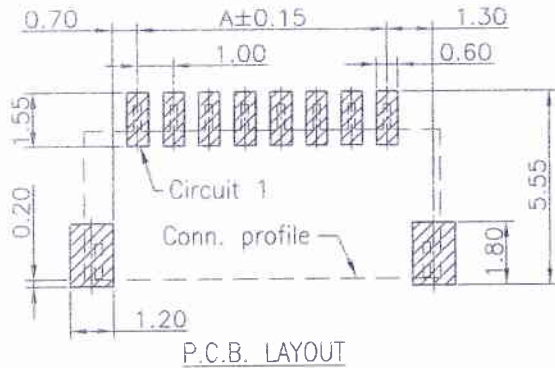

P.C.B. LAYOUT

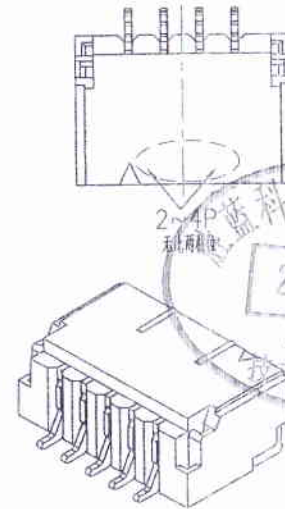
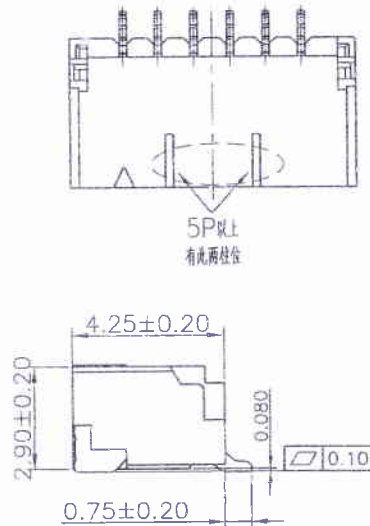
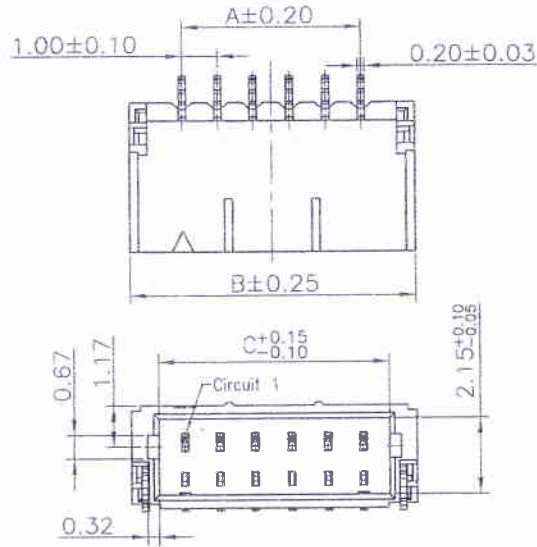

Circuits Part No	Dimensions		
	A	B	C
2P	--	4.00	2.45
3P	2.00	5.00	3.45
4P	3.00	6.00	4.45
5P	4.00	7.00	5.45
6P	5.00	8.00	6.45
7P	6.00	9.00	7.45
8P	7.00	10.00	8.45
9P	8.00	11.00	9.45
10P	9.00	12.00	10.45
11P	10.00	13.00	11.45
12P	11.00	14.00	12.45
13P	12.00	15.00	13.45
14P	13.00	16.00	14.45
15P	14.00	17.00	15.45
16P	15.00	18.00	16.45
17P	16.00	19.00	17.45
18P	17.00	20.00	18.45
19P	18.00	21.00	19.45
20P	19.00	22.00	20.45
21P	20.00	23.00	21.45

Part No.	Material	Color	Pin Material	Solder Tabs
11002W90-NP-SA-H1-5A-HF-R	High temperature plastic,UL94V-0	Beige	Phosphor Bronze/Gold-flash	Phosphor Bronze/Gold-flash
11002W90-NP-SA-H1-3E-HF-R	High temperature plastic,UL94V-0	Beige	Phosphor Bronze/Matte Tin Plated	Phosphor Bronze/Matte Tin Plated
11002W90-NP-SA-H1-5AE-HF-R	High temperature plastic,UL94V-0	Beige	Phosphor Bronze/Gold-flash	Phosphor Bronze/Tin-plated
11002W90-NPA-SA-H1-HF-R	High temperature plastic,UL94V-0	Black	Phosphor Bronze/Tin-plated	Phosphor Bronze/Tin-plated

REV.	REVISION RECORD	DATE	GENERAL TOLERANCES	SCALE:	NAME	DATE	PART NO:	DWG. NO:
A0	新图面发行	17. 10. 13	LINER	1:1			11002W90-NP-SA-H1-XX-HF	ENDE05
A1	WN1911210279	17. 10. 13	0.0±0.25	APPROVED	张振坤	20.03.05		
A2	WN2003050029	20. 03. 05	0.00±0.15	DESIGNER	张振坤	20.03.05	TITLE:	
			0.000±0.08	DRAWN	张振坤	20.03.05	JST 1.00mm PITCH CONN	



2~13 Contacts

14~21 Contacts

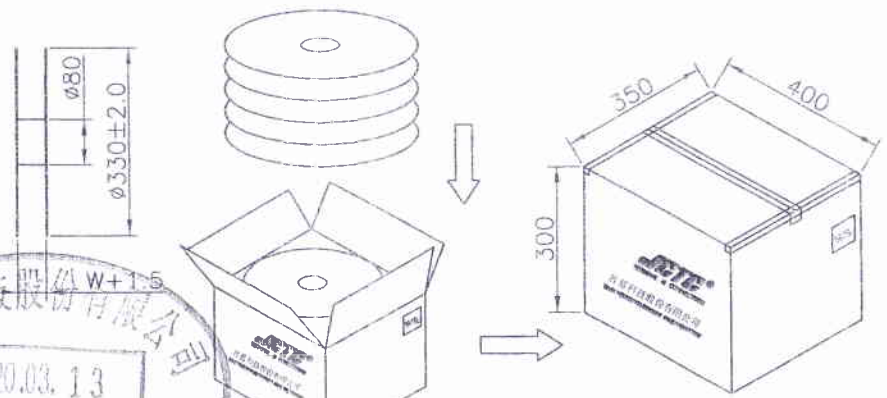
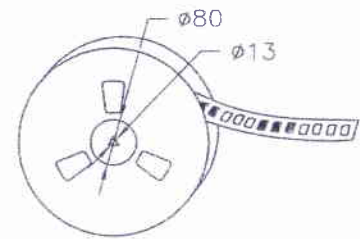
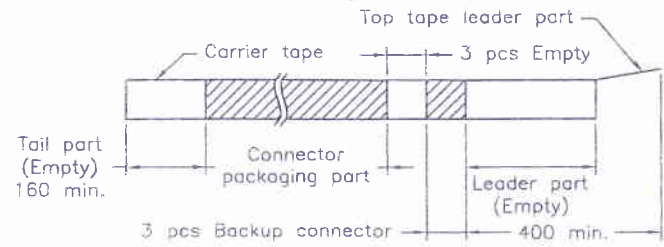
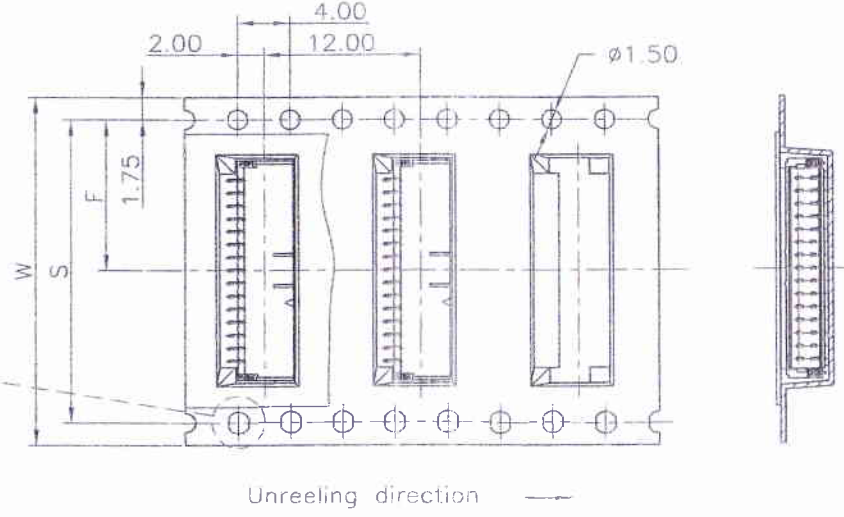
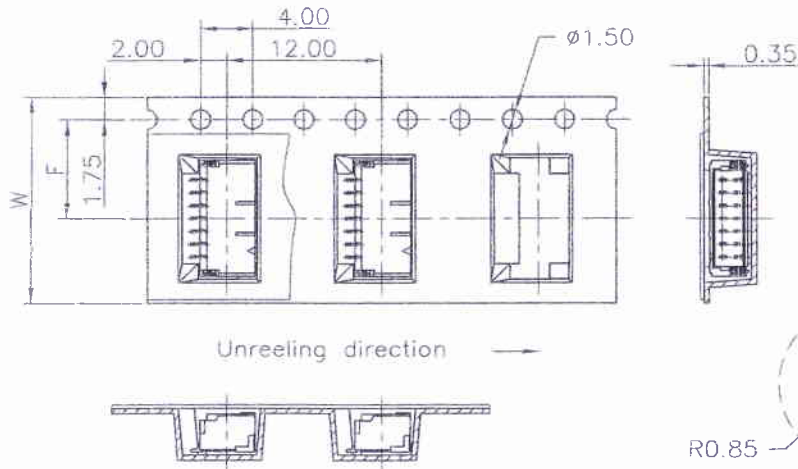

Number of Contacts	W±0.3	F±0.1	S±0.1	Q'ty/Reel	Q'ty/Box
2P-6P	16	7.50	/	1,500	21,000
7P-13P	24	11.50		1,500	15,000
14P-19P	32	14.20	28.40	1,500	12,000
20P-21P	44	20.20	40.40	1,500	9,000

REV.	REVISION RECORD	DATE		GENERAL TOLERANCES		SCALE: 1:1	NAME	DATE	PART. NO:	DWG. NO:
A0	新图面发行	17.10.13			LINEAR	ANGLES				11002W90-NP-SA-H1-XX-HF
A1	WN1908150196	19.08.15		0.0±0.25	X° REF±6°	APPROVED	张振坤	20.03.05	TITLE: JST 1.00mm PITCH CONN	 TERMINAL & CONNECTORS
A2	WN2003050029	20.03.05	UNIT: MM	0.00±0.15	X° ±3°	DESIGNER	张振坤	20.03.05		
			SIZE: A1	0.000±0.08	X° X'±2°	DRAWN	张振坤	20.03.05		

