

RoHS

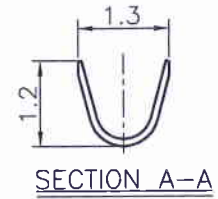

SECTION A-A

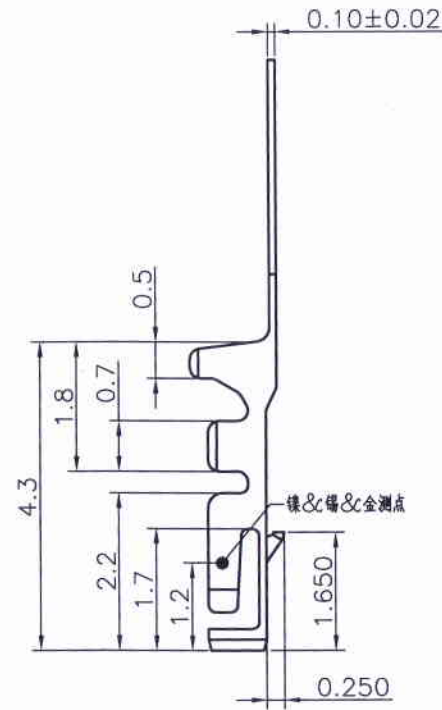
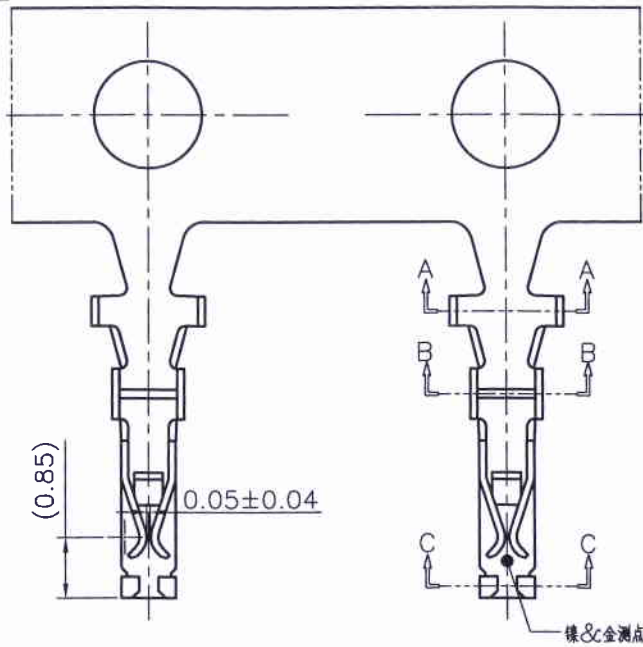
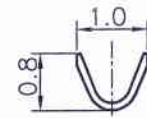

SECTION B-B

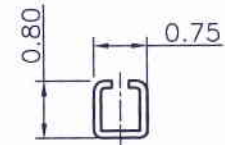

SECTION C-C

PART NO.
11005T1P-XX-NK

Finish 0*--镀半金锡

0A--Gold-flash 0B--2u" 0C--3u"
0D--4u" 0E--5u" 0F--10u"
0G--15u" 0H--30u" 0I--50u"

Finish 5*--镀全金

5A--Gold-flash 5B--2u" 5C--3u"
5D--4u" 5E--5u" 5F--10u"
5G--15u" 5H--30u" 5I--50u"

Part No	Wire Range	Insulation O.D.	Material	Finish	Qty/reel
11005T1P-5X-NK	AWG#32~#34	0.60mm(max)	Phosphor bronze	Gold-plated	20,000PCS
11005T1P-2E-NK	AWG#32~#34	0.60mm(max)	Phosphor bronze	Tin-plated 60u"	20,000PCS
11005T1P-0X-NK	AWG#32~#34	0.60mm(max)	Phosphor bronze	Gold-flash	20,000PCS

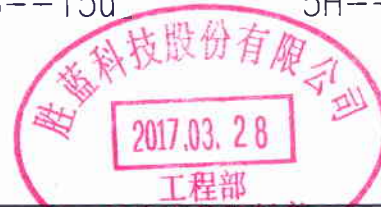

REV.	REVISION RECORD	DATE	GENERAL TOLERANCES	SCALE:	NAME	DATE						
C2	ECN1012130154	10.12.13	<table border="1"> <tr> <td>LINEAR</td> <td>ANGLES</td> </tr> <tr> <td>0.0±0.25</td> <td>X° REF±6°</td> </tr> </table>	LINEAR	ANGLES	0.0±0.25	X° REF±6°	1:1	卢小锋	8/3/17		
LINEAR	ANGLES											
0.0±0.25	X° REF±6°											
C3	ECN1103290052	11.03.29	<table border="1"> <tr> <td>UNIT: MM</td> <td>0.00±0.15</td> <td>X° ±3°</td> </tr> <tr> <td>SIZE: A4</td> <td>0.000±0.08</td> <td>X° X'±2°</td> </tr> </table>	UNIT: MM	0.00±0.15	X° ±3°	SIZE: A4	0.000±0.08	X° X'±2°	APPROVED	卢小锋	8/3/17
UNIT: MM	0.00±0.15	X° ±3°										
SIZE: A4	0.000±0.08	X° X'±2°										
C4	TN1312240227	13.12.24	DESIGNER	卢小锋	17.03.27							
C5	变更公司名称	17.03.27		DRAWN	卢小锋	17.03.27						

JCTC 胜蓝科技股份有限公司
TERMINAL&CONNECTORS 东莞市富智达电子科技有限公司

TITLE: 88252 端子(低脚)

PART NO:	11005T1P-XX-NK
DWG NO:	ENDE05
REV:	C5
SHEET:	1/1