

RoHS

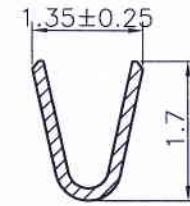

Section A-A

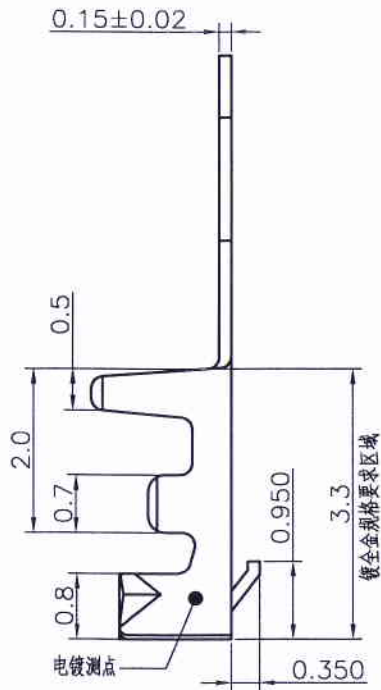
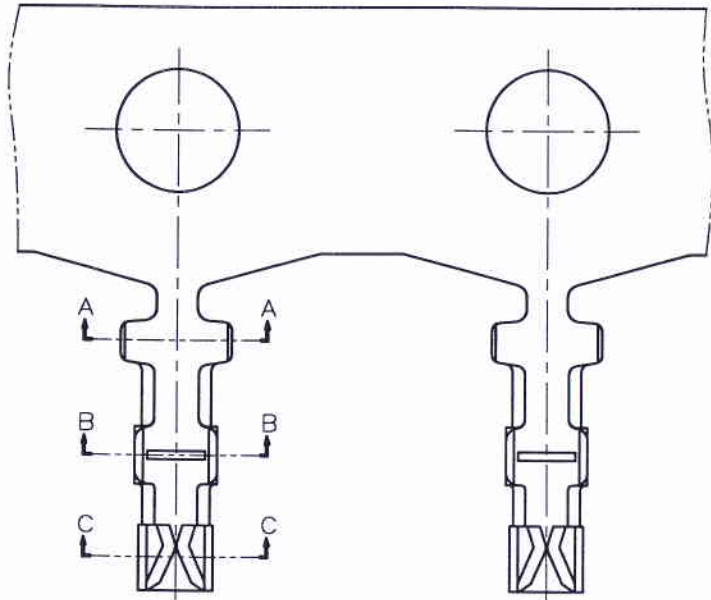
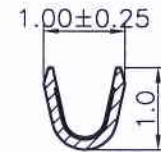

Section B-B

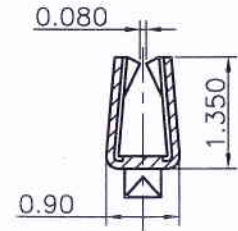

Section C-C



Note: 11251TOP-XX-C-NK

NK: No Mark

表示: 有缝隙规格

Finish

- 5A--Gold flash 5B--2u" 5C--3u"
- 5D--4u" 5E--5u" 5F--10u"
- 5G--15u" 5H--30u" 5I--50u"

Part No	Wire Range	Insulation O.D.	Material	Finish	Qty/reel
11251TOP-2E-C-XX	AWG#28 ~ #32	1.00mm(max)	Phosphor Bronze	Tin-plated	15,000 pcs
11251TOP-5X-C-XX	AWG#28 ~ #32	1.00mm(max)	Phosphor Bronze	Gold-plated overall	15,000 pcs

REV.	REVISION RECORD	DATE	UNIT: MM	GENERAL TOLERANCES		SCALE: 1:1	NAME	DATE	JCTC ® 胜蓝科技股份有限公司 TERMINAL&CONNECTORS 东莞市富智达电子科技有限公司	PART. NO:			
C0	换图框发行	09.12.21		LINEAR	ANGLES	APPROVED				11251TOP-XX-C-XX			
C1	TN1010120097	10.10.12	SIZE: A4	0.0±0.25	X° REF±6°	DESIGNER		16.11.22	TITLE: MX1.25 端子	DWG. NO:			
C2	TR1105310082	11.05.31		0.00±0.15	X° ±3°					DRAWN	邓群庄	16.11.22	ENDE05
C3	TN1611220188	16.11.22		0.000±0.08	X° X'±2°								