

RoHS

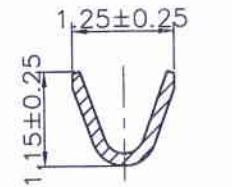

SECTION A-A

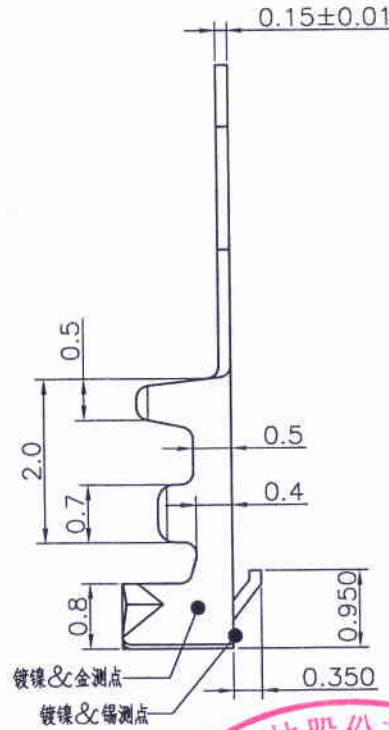
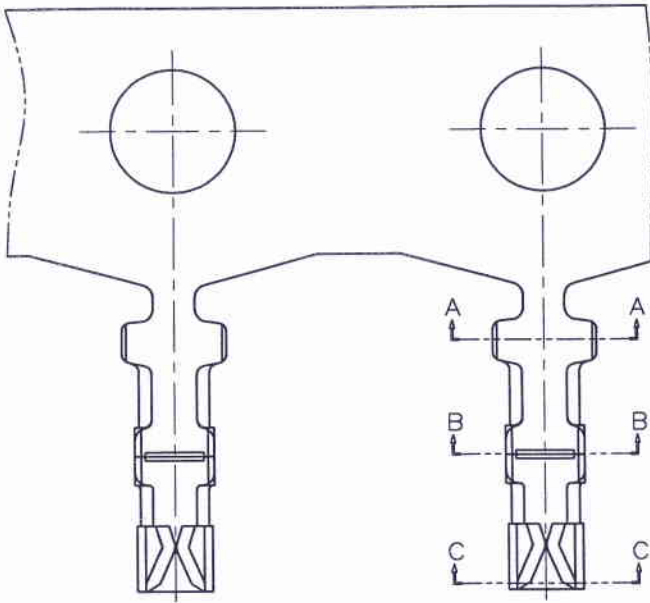
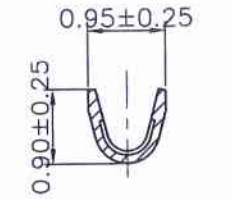

SECTION B-B

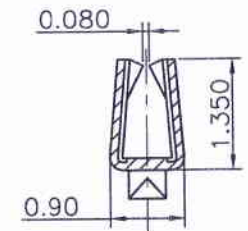

Section C-C

Note: 11251T1P-XX-C-NK
 NK: No Mark
 Finish TYPE
 5A--Gold-flash 5B--2u" 5C--3u"
 5D--4u" 5E--5u" 5F--10u"
 5G--15u" 5H--30u" 5I--50u"
 2E--Tin-plated



Part No	Wire Range	Insulation O.D.	Material	Finish	Qty/reel
11251T1P-2E-C-XX	AWG #34	0.60mm(max)	Phospor Bronze	Ni30μ"Min, Sn70μ"Min	15,000 pcs
11251T1P-5X-C-XX	AWG #34	0.60mm(max)	Phospor Bronze	Gold-plated overall	15,000 pcs

REV.	REVISION RECORD	DATE	GENERAL TOLERANCES	SCALE:	NAME	DATE
C2	TN1011030121	10.11.03	LINEAR ANGLES 0.0±0.25 X° REF±6°	1:1	APPROVED	
C3	TN1105160071	11.05.16		0.00±0.15 X° ±3°	DESIGNER	邓群庄
C4	TN1310230182	13.10.28	UNIT: MM	DRAWN	邓群庄	16.12.26
C5	更换公司名称	16.12.26	SIZE: A4			

JCTC ® 胜蓝科技股份有限公司 TERMINAL&CONNECTORS 东莞市富智达电子科技有限公司		PART. NO: 11251T1P-XX-C-XX
TITLE: MX1.25 低脚端子		DWG. NO: ENDE05
REV: C5	SHEET: 1/1	