

1 2 3 4 5 6 7 8

A
B
C
D
E
F
G
H

A
B
C
D
E
F
G
H

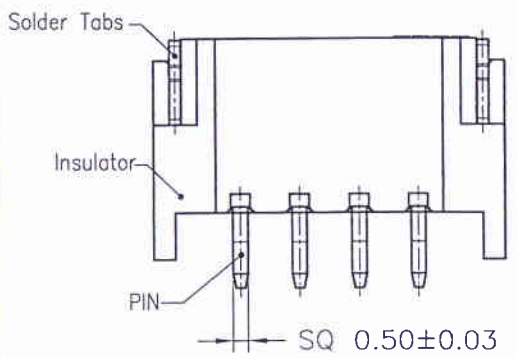
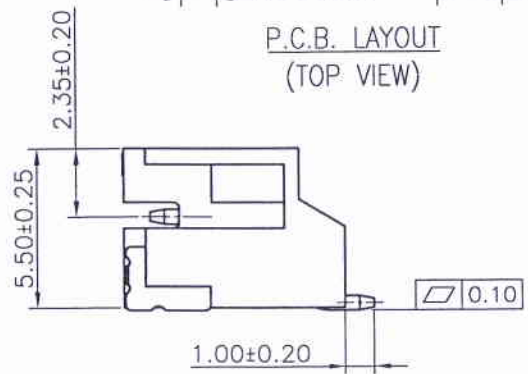
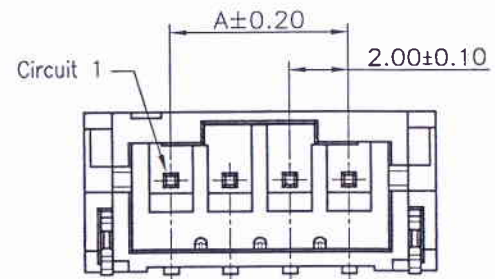
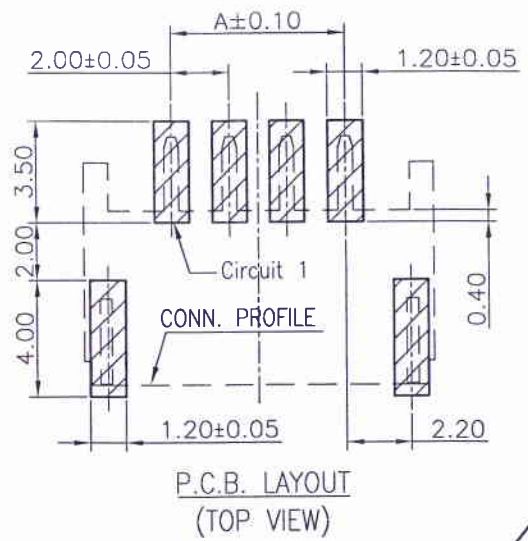
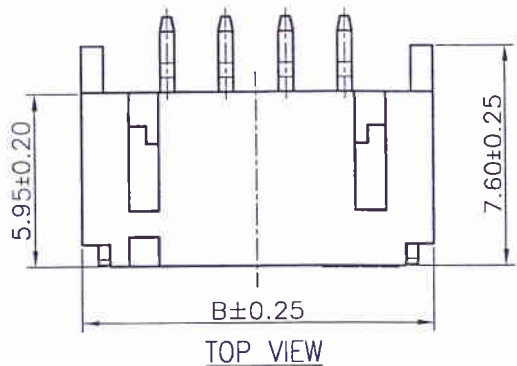

Specifications:
 Rated Voltage : 100V AC/DC
 Rated Current : 2A AC,DC
 Withstand Voltage : 800V AC/minute
 Contact Resistance : 10mΩ(Max.)
 Insulation Resistance : 1000MΩ(Min.)
 Temperature Range : -25°C~+85°C
 The product using material and processing must conform to the "WI-PZ-142"HSF technical standard control requirements

PART NO.	Dimensions	
	A	B
2P	--	8.00
3P	4.00	10.00
4P	6.00	12.00
5P	8.00	14.00
6P	10.00	16.00
7P	12.00	18.00
8P	14.00	20.00
9P	16.00	22.00
10P	18.00	24.00
11P	20.00	26.00
12P	22.00	28.00
13P	24.00	30.00
14P	26.00	32.00
15P	28.00	34.00
16P	30.00	36.00

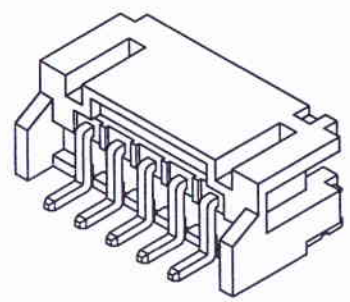

12001W90-NP-S-XX-HF-NK-R
 ① ② ③ ④ ⑤ ⑥ ⑦ ⑧

- ① Series No.
- ② W90 : Side Contact
W00 : Up Contact
- ③ No. of Circuits
- ④ S: SMT Type
- ⑤ 3E : Matte Tin-plated
- ⑥ HF: Halogen Free
- ⑦ NK: NO Mark
- ⑧ R : Reel pack



Part No.	Material	Color	PIN Material	Solder Tabs
12001W90-NP-S-HF-NK-R	LCP,UL94V-0	Natural(Beige)	Brass/Tin-plated	Brass/Tin-plated
12001W90-NPA-S-3E-HF-NK-R	LCP,UL94V-0	Black	Brass/Matte Tin-plated	Brass/Matte Tin-plated

REV.	REVISION RECORD	DATE	GENERAL TOLERANCES	SCALE:	NAME	DATE	JCTC® 胜蓝科技股份有限公司 TERMINAL&CONNECTORS 东莞市富智达电子科技有限公司	PART. NO.:
C0	新图面发行	14.05.05	LINEAR	1:1				
C1	WN1601200011	16.01.20	ANGLES	APPROVED				DWG. NO.:
C2	更新公司名称	17.12.01	0.0±0.25	DESIGNER				ENDE05
			0.00±0.15	DRAWN	伍文聪	17.12.01		REV: C2 SHEET: 1/2
			0.000±0.08					

1 2 3 4 5 6 7 8

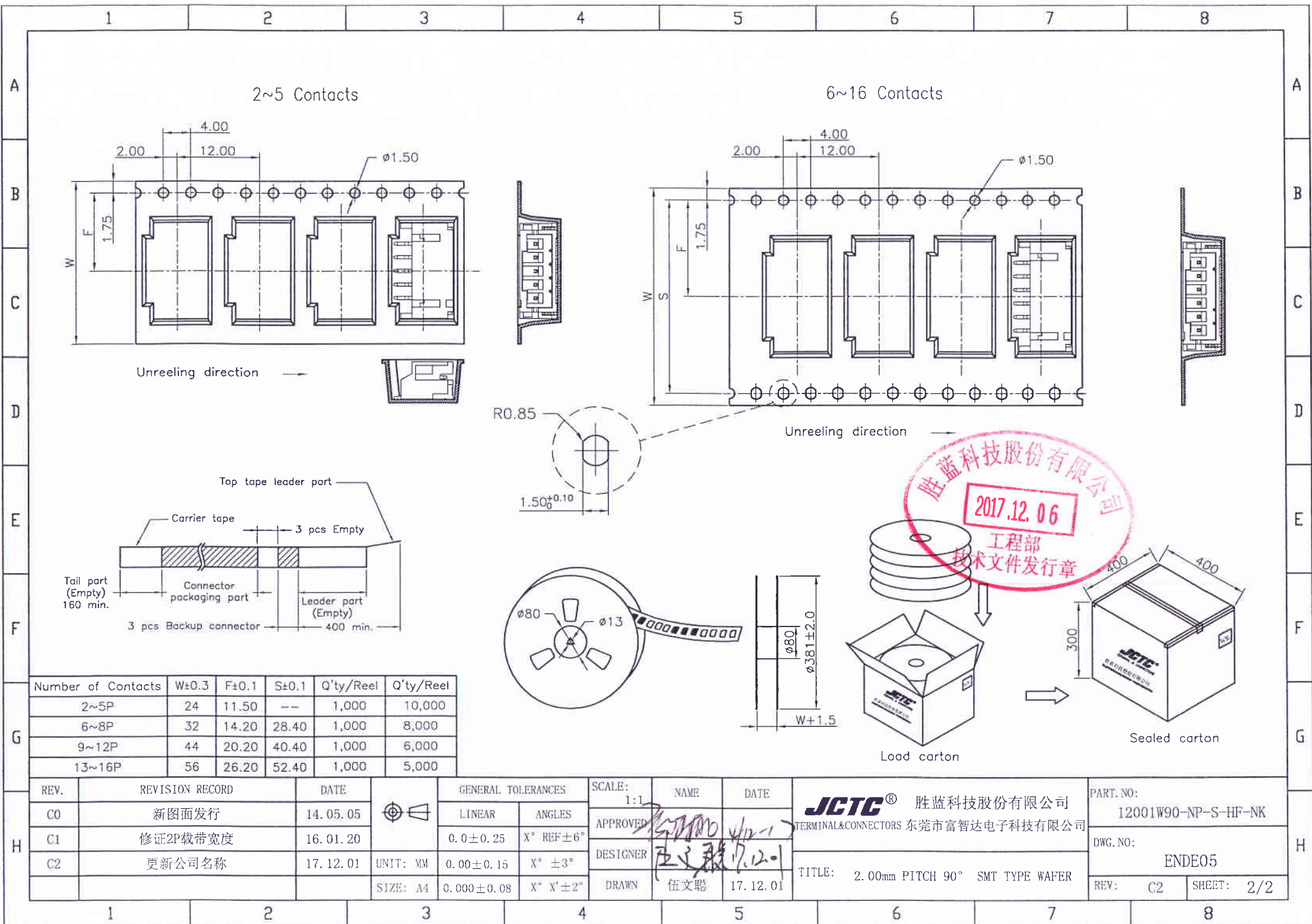

Number of Contacts	W±0.3	F±0.1	S±0.1	Q'ty/Reel	Q'ty/Reel
2~5P	24	11.50	--	1,000	10,000
6~8P	32	14.20	28.40	1,000	8,000
9~12P	44	20.20	40.40	1,000	6,000
13~16P	56	26.20	52.40	1,000	5,000

REV.	REVISION RECORD	DATE	
C0	新图面发行	14.05.05	
C1	修证2P载带宽度	16.01.20	
C2	更新公司名称	17.12.01	
			UNIT: MM
			SIZE: A4

GENERAL TOLERANCES	
LINEAR	ANGLES
0.0±0.25	X° REF±6°
0.00±0.15	X° ±3°
0.000±0.08	X° X'±2°

SCALE:	NAME	DATE
1:1		
APPROVED		17.12.01
DESIGNER	伍文聪	
DRAWN	伍文聪	17.12.01

JCTC ® 胜蓝科技股份有限公司
TERMINAL&CONNECTORS 东莞市富智达电子科技有限公司
TITLE: 2.00mm PITCH 90° SMT TYPE WAFER

PART. NO:	12001W90-NP-S-HF-NK
DWG. NO:	ENDE05
REV:	C2
SHEET:	2/2