

Specifications:  
 Rated Voltage : 100V AC/DC  
 Rated Current : 2A AC,DC  
 Withstand Voltage : 800V AC/minute  
 Contact Resistance : 10mΩ(MAX.)  
 Insulation Resistance : 1000MΩ(MIN.)  
 Temperature Range : -25°C~+85°C  
 The product using material and processing must conform to the "WI-PZ-142" HSF technical standard control requirements

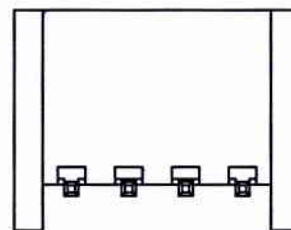
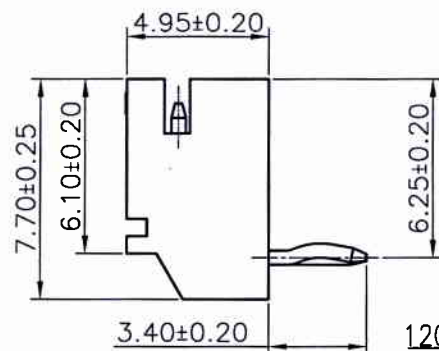
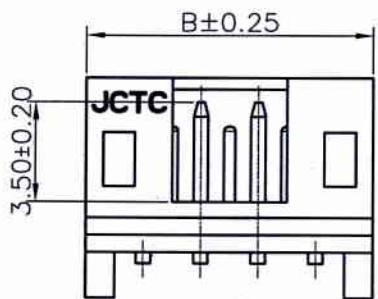
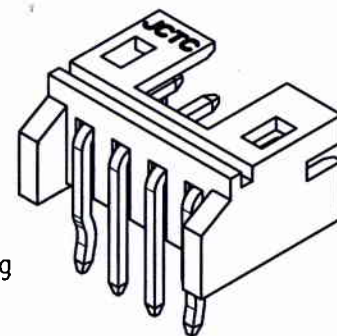

Circuits	Dimensions	
	A	B
2P	2.00	6.00
3P	4.00	8.00
4P	6.00	10.00
5P	8.00	12.00
6P	10.00	14.00
7P	12.00	16.00
8P	14.00	18.00
9P	16.00	20.00
10P	18.00	22.00
11P	20.00	24.00
12P	22.00	26.00
13P	24.00	28.00
14P	26.00	30.00
15P	28.00	32.00
16P	30.00	34.00

12001W90-NPX-S3-HF  
 ① ② ③ ④ ⑤

- ① Series No.
- ② W90 : Side Contact  
W00 : Up Contact
- ③ No. of Circuits
- ④ X : Product color(A--Y)  
Blank : Natural type    A : Black
- ⑤ S3 : S3 Type
- ⑥ HF : Halogen Free

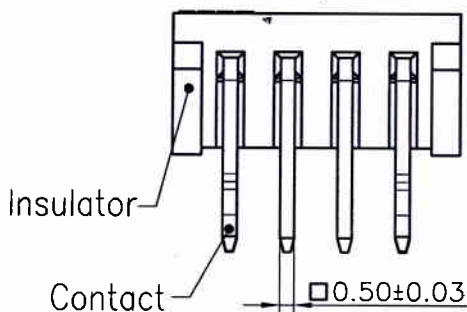

Part No.	Material	Color	PIN Material
12001W90-NP-S3-HF	Thermal Plasticity Resin, UL94V-0	Natural(Beige)	Brass/Tin-plated
12001W90-NPA-S3-HF	Thermal Plasticity Resin, UL94V-0	Black	Brass/Tin-plated

REV.	REVISION RECORD	DATE	UNIT	SIZE	GENERAL TOLERANCES	SCALE:	NAME	DATE	JCTC® 胜蓝科技股份有限公司	PART. NO.:
C0	新图面发行	13. 10. 23	MM	A4	LINEAR: 0.0±0.25 ANGLES: X° REF±6°	1:1	APPROVED	9/9/19	TERMINAL&CONNECTORS 东莞市富智达电子科技有限公司	12001W90-NP-S3-HF
C1	更新公司名称	17. 12. 01	MM	A4	0.00±0.15 X° ±3°		DESIGNER	19.08.05		DWG. NO.:
C2	WN1909050216	19. 08. 25	MM	A4	0.000±0.08 X° X'±2°		DRAWN	伍文聪	19. 08. 25	ENDE05
TITLE: 2.00mm PITCH DIP TYPE 90° WAFER										REV: C2 SHEET: 1/1