

环保物料

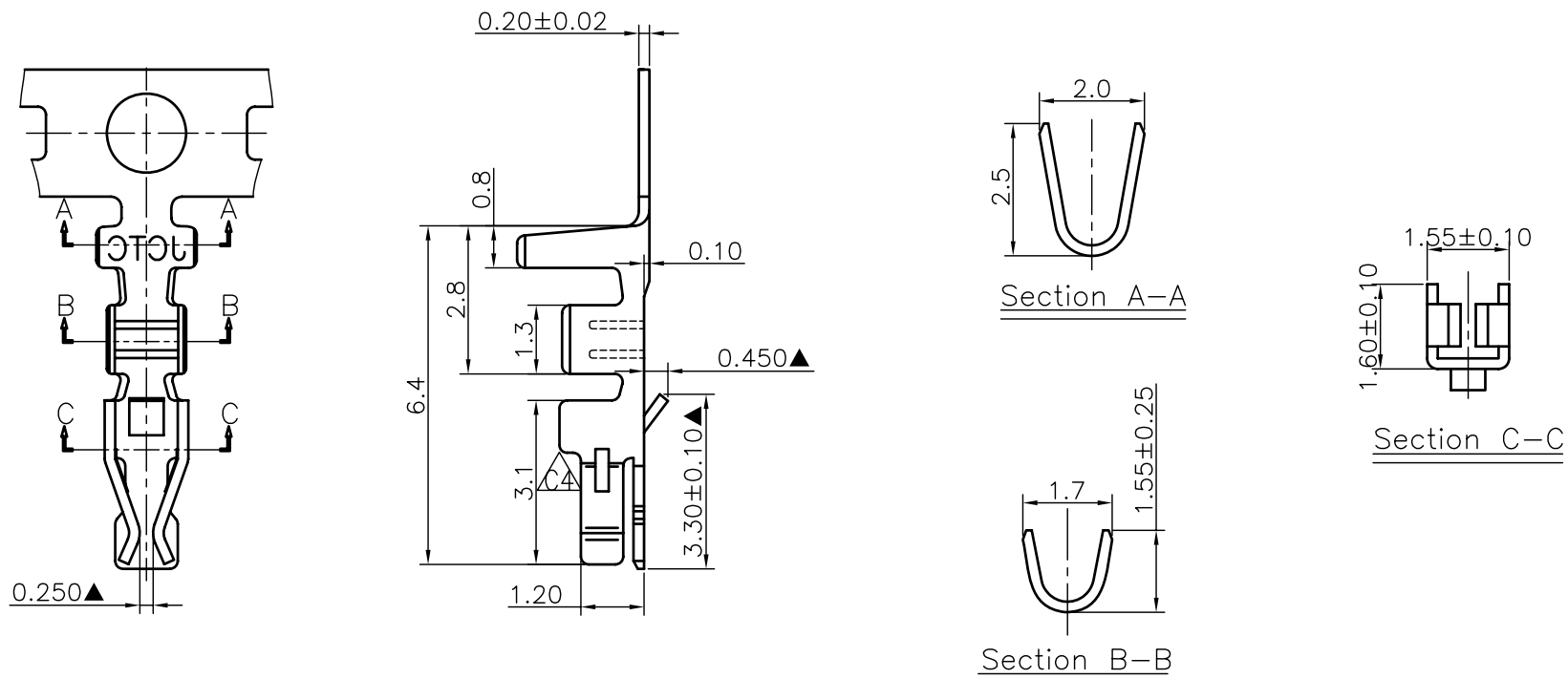

Specification & Ordering Information:

Part No	Wire Range	Insulation O.D.	Material	Finish	Qty/reel	Note
12002TOP-2	AWG #24~#28	1.50mm(max)	Phosphor Bronze	Tin-plated On Ni	10,000 PCS	Stamping after plating
12002TOP-2-NK	AWG #24~#28	1.50mm(max)	Phosphor Bronze	Tin-plated On Ni	10,000 PCS	Stamping after plating

REV.	REVISION RECORD	DATE		GENERAL TOLERANCES		SCALE:	NAME	DATE	JCTC ® <input type="checkbox"/> 苏州伟聚 <input type="checkbox"/> 东莞胜景 TERMINAL&CONNECTORS <input checked="" type="checkbox"/> 东莞胜蓝	PART. NO:	
C1	新增规格及取消相关尺寸	10.12.29		LINEAR	ANGLES	1:1				APPROVED	王志刚
C2	TR1105310082	11.05.31	0.00±0.25	X° REF±6°		DESIGNER	欧阳小强	11.11.15		DWG. NO:	
C3	TN1110220143	11.10.22	0.00±0.15	X° ±3°		DRAWN	伍文聪	11.11.15		ENDE05	
C4	TN1111150147	11.11.15	UNIT: MM	0.000±0.08	X° X'±2°				TITLE:	REV: C4	SHEET: 1/1

PHD2.0端子