

环保物料

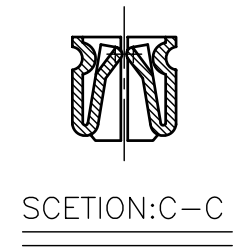

Part No	Wire Range	Insulation O.D.	Material	Finish	Qty/reel
12006TOP-2	AWG#24~#30	1.40mm(max)	Phosphor bronze	Tin-plated	10,000PCS

			一般公差 GENERAL TOLERANCE		绘图 DR.	EAST	JCTC 东莞市胜蓝电子有限公司 — 富强电子厂 —	料号 PART NO. 12006TOP-2		
			X.X ±0.25	X' ±5°	校对 CHK.	唐海江		文件编号 NUMBER ENDE05		
			X.XX ±0.15	X.X' ±2°	审核 CHK.	龚友莲		比例 SCALE SHEET 版次 REV. 1/1 1/1 C1		
C1	10.10.11	图面与实物不符, 修正图面	龚友莲	唐海江	单位 UNIT	核准 APPD.	王志刚	品名 TITLE MOLEX2.0端子		
CO	10.01.19	换图框发行	EAST	唐海江	mm					
版次 REV.	日期 DATE	变更内容 DESCRIPTION	审核 CHK.	核准 APPD.						

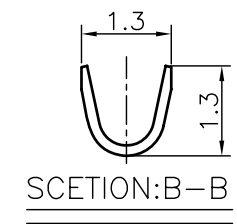
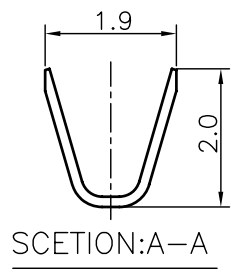
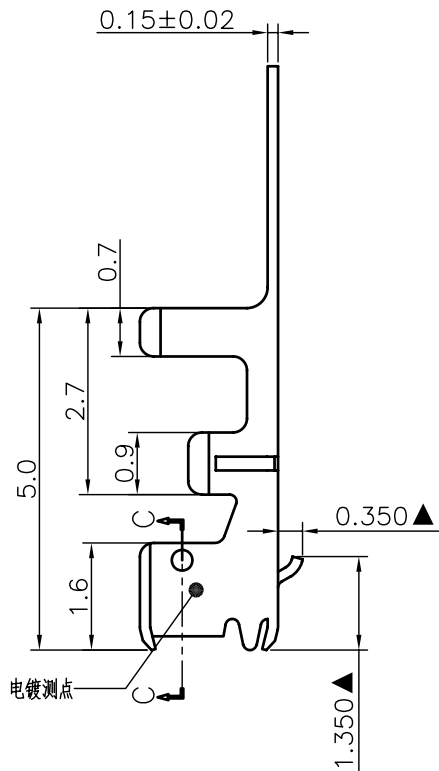
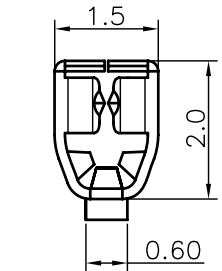
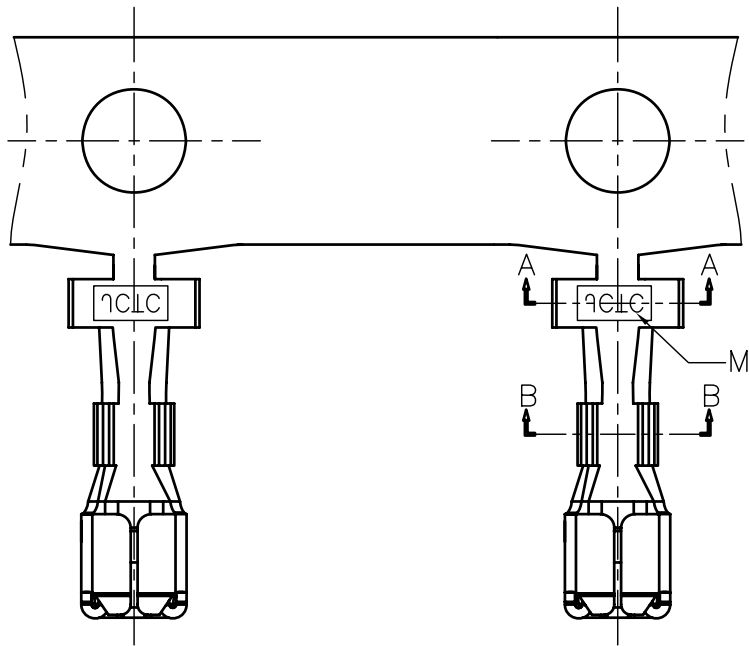
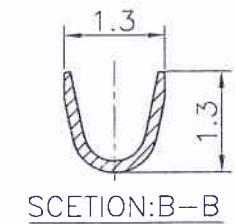
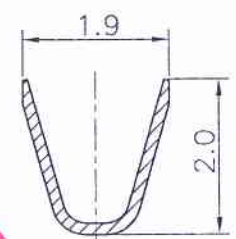
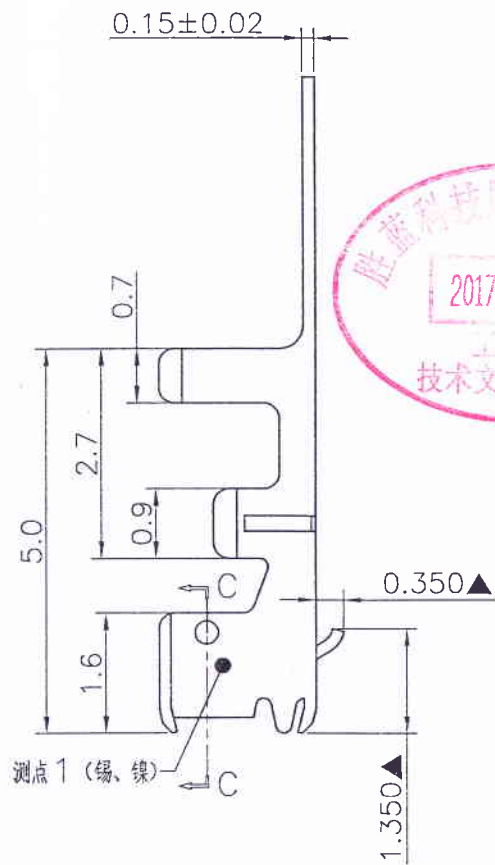
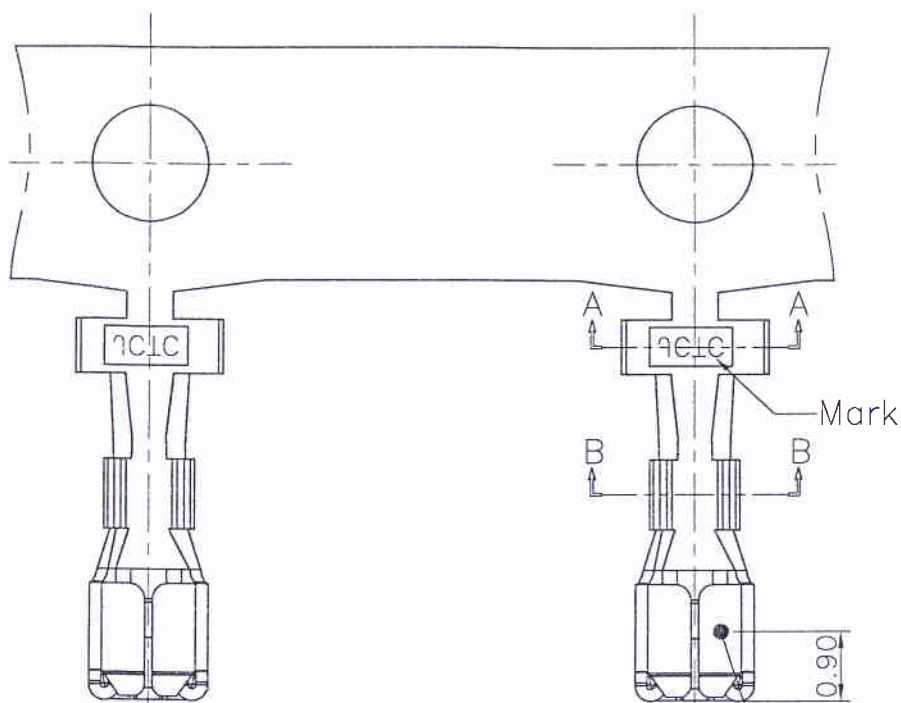

The product using material and processing must conform to the "WI-PZ-142" HSF technical standard control requirements

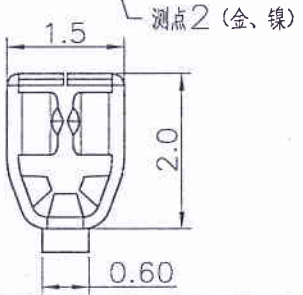

12006TOP-XX

- Finish
- 0A: Gold flash on contact Area
  - 0B: 2u"Au on contact Area
  - 0C: 3u"Au on contact Area
  - 0E: 5u"Au on contact Area
  - 0G: 15u"Au on contact Area

Part No	Wire Range	Insulation O.D	Material	Finish	Qty/reel
12006TOP-2	AWG#24~#30	1.40mm(max)	Phosphor bronze	Tin-plated(先镀后冲)	10,000PCS
12006TOP-2E	AWG#24~#30	1.40mm(max)	Phosphor bronze	Tin-plated(先冲后镀)	10,000PCS
12006TOP-0X	AWG#24~#30	1.40mm(max)	Phosphor bronze	Au on contact Area	10,000PCS

REV.	REVISION RECORD	DATE	UNIT: MM	GENERAL TOLERANCES		SCALE: 1:1	NAME	DATE
				LINEAR	ANGLES			
C2	增加电镀规格	15.07.27	SIZE: A4	0.0±0.25	X° REF±6°	APPROVED	伍文聪	17.10.17
C3	增加镀半金规格	16.03.07		0.00±0.15	X° ±3°	DESIGNER		
C4	TR1607050096	16.03.07		0.00±0.15	X° ±3°	BROWN		
C5	更换公司名称	17.10.17		0.000±0.08	X° X'±2°			

<b>JCTC</b> ® 胜蓝科技股份有限公司 TERMINAL&CONNECTORS 东莞市富智达电子科技有限公司	PART. NO:	12006TOP-XX
	DWG. NO:	ENDE05
TITLE:	1.0mm PITCH 双排 Housing	
REV:	C5	SHEET: 1/1