

RoHS

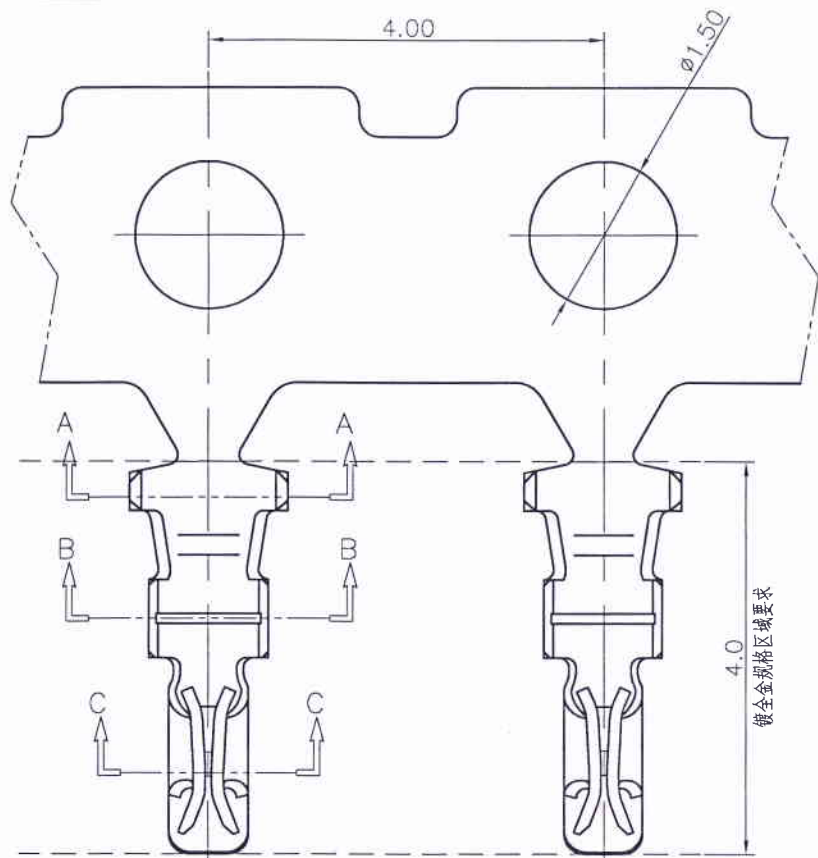

镀金规格区域要求

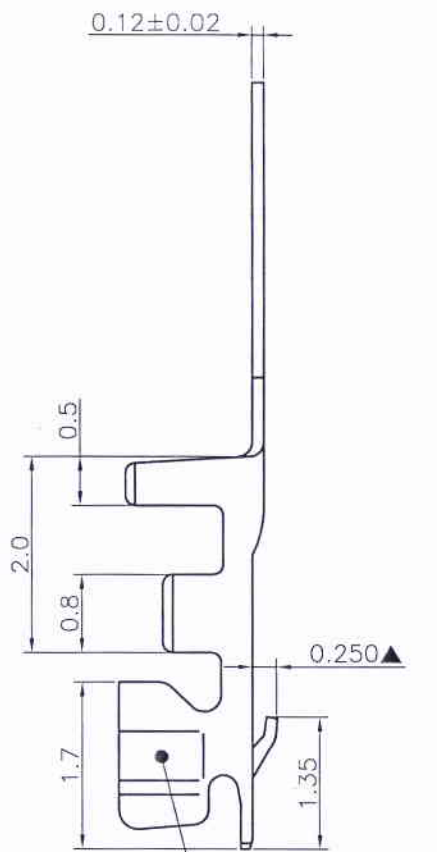

PIN内测为电镀膜厚测点

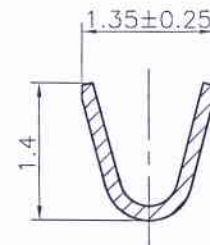

SECTION A-A

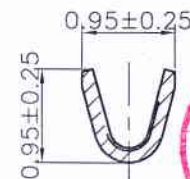

SECTION B-B

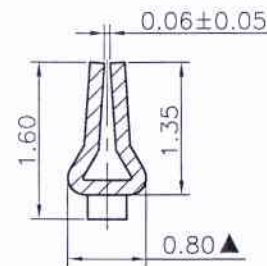

SECTION C-C



Specification & Ordering Information:

Part No	Wire Range	Insulation O.D.	Material	Finish	Qty/reel
11002TOP-5H-G-NK	AWG #28~#32	0.80mm(max)	Phosphor Bronze	Ni. 50u"Min., Gold Plated 30u" on Contact Area.	2,0000 PCS

REV.	REVISION RECORD	DATE	GENERAL TOLERANCES	SCALE:	NAME	DATE	PART. NO: 11002TOP-5H-G-NK
A0	新图面发行	16.09.28	LINEAR 0.0±0.25	1:1	APPROVED	16.09.28	
			ANGLES X° REF±6°		DESIGNER	16.09.28	DWG. NO: ENDE05
			UNIT: MM 0.00±0.15		DRAWN	16.09.28	
			SIZE: A4 0.000±0.08				REV: A0
TITLE: JST1.0端子 松端							SHEET: 1/1

JCTC 胜蓝科技股份有限公司
TERMINAL&CONNECTORS 东莞市富智达电子科技有限公司

JST1.0端子 松端