

**SPECIFICATIONS**  
 Voltage Rating: 50V AC,DC  
 Current Rating: 1A AC,DC  
 Withstanding Voltage: 500V AC/minute  
 Contact Resistance: 20mΩ Max.  
 Insulation Resistance: 100MΩ Min.  
 Temperature Range: -25°C ~ +85°C  
 The product using material and processing must conform to the "WI-PZ-142" HSF technical standard control requirements

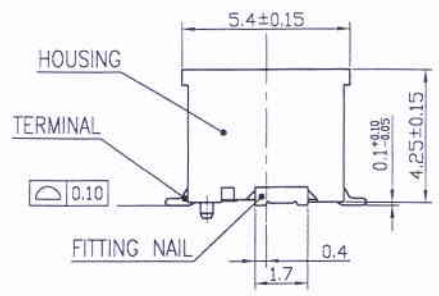
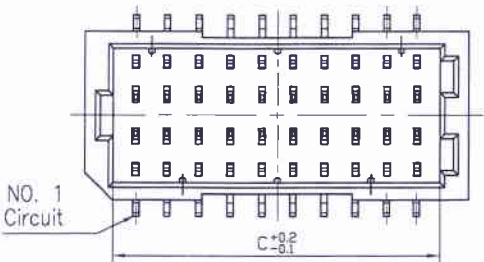

11002W00-2XNP A-S F-S6-2M-HF  
 ① ② ③ ④ ⑤ ⑥ ⑦ ⑧ ⑨

- ① Series No.
- ② W90 : Side Contact  
W00 : Up Contact
- ③ No. of Circuits
- ④ Color: A=Black
- ⑤ S: SMT type
- ⑥ F : With Boss
- ⑦ S6 : S6 Type
- ⑧ 2M : Matter Tin-Plating
- ⑨ HF : Halogen Free

Dimensional Ordering Information:		
Circuits Part No	Dimensions	
	A	B
2X5P	4.00	7.30
2X6P	5.00	8.30
2X8P	7.00	10.30
2X9P	8.00	11.30
2X10P	9.00	12.30
2X12P	11.00	14.30
2X15P	14.00	17.30
2X20P	19.00	22.30
2X25P	24.00	27.30

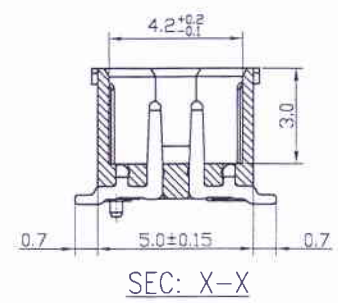
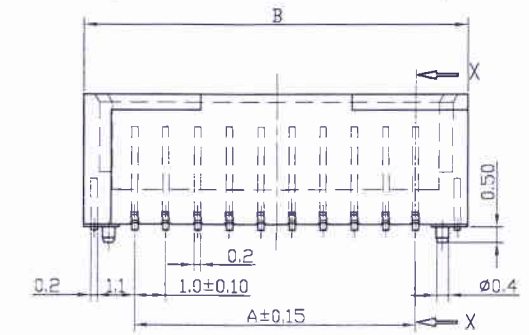

Part No.	Material	Color	Pin Material	Solder Tabs
11002W00-2XNPA-SF-S6-2M-HF	LCP,UL94V-0	Black	Phosphor Bronze/Matter Tin-Plating	Brass/Matter Tin-Plating

REV.	REVISION RECORD	DATE	GENERAL TOLERANCES	SCALE:	NAME	DATE	PART NO:	DWG. NO:	<b>JCTC</b> <sup>®</sup> TERMINAL&CONNECTORS	
A0	新图面发行	20.08.07	LINEAR	1:1			11002W00-2XNPA-SF-S6-2M-HF	ENDE05		
			ANGLES	APPROVED						
			UNIT: MM	DESIGNER			TITLE:			
			SIZE: A4	DRAWN	陈佳龙	20.08.07	JST 1.00mm PITCH 无盖双排带防呆柱 CONN.		REV: A0	SHEET: 1/2

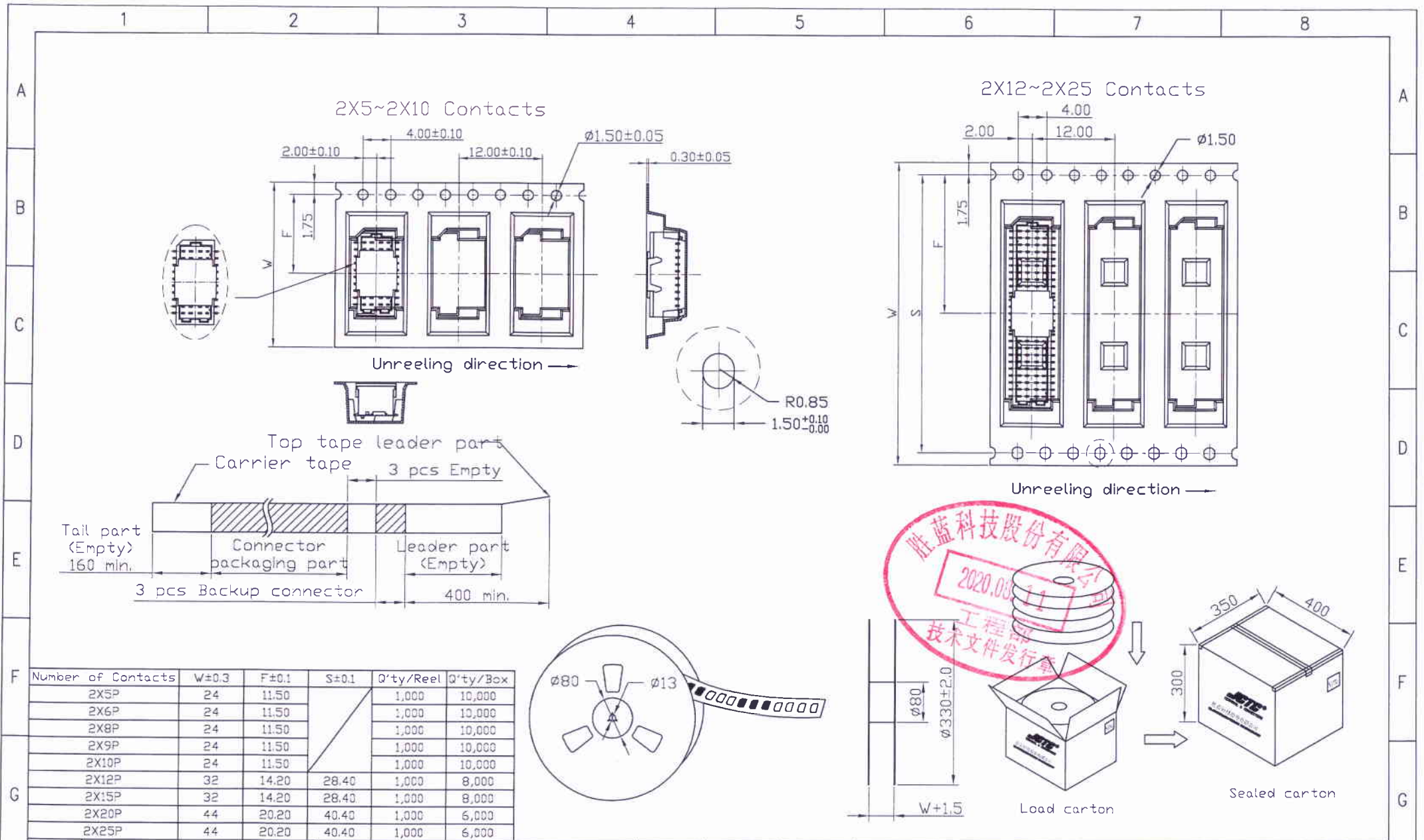

Number of Contacts	W±0.3	F±0.1	S±0.1	Q'ty/Reel	Q'ty/Box
2X5P	24	11.50	/	1,000	10,000
2X6P	24	11.50		1,000	10,000
2X8P	24	11.50		1,000	10,000
2X9P	24	11.50		1,000	10,000
2X10P	24	11.50		1,000	10,000
2X12P	32	14.20	28.40	1,000	8,000
2X15P	32	14.20	28.40	1,000	8,000
2X20P	44	20.20	40.40	1,000	6,000
2X25P	44	20.20	40.40	1,000	6,000

REV.	REVISION RECORD	DATE	GENERAL TOLERANCES	SCALE: 1:1	NAME	DATE	PART. NO:	DWG. NO:	JCTC® TERMINAL&CONNECTORS
A0	新图面发行	20.08.07	LINEAR C. 0 ± 0.25	APPROVED	陈佳龙	20.08.07	11002W00-2XNPA-SF-S6-2X-HF	ENDE05	
			ANGLES C. 00 ± 0.15	DESIGNER	陈佳龙	20.08.07	TITLE: JST 1.00mm PITCH 无盖双排带防呆柱 CONN.		
			UNIT: MM C. 00 ± 0.08	DRAWN	陈佳龙	20.08.07	REV: A0	SHEET: 2/2	