

RoHS

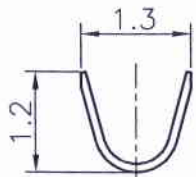

SECTION A-A

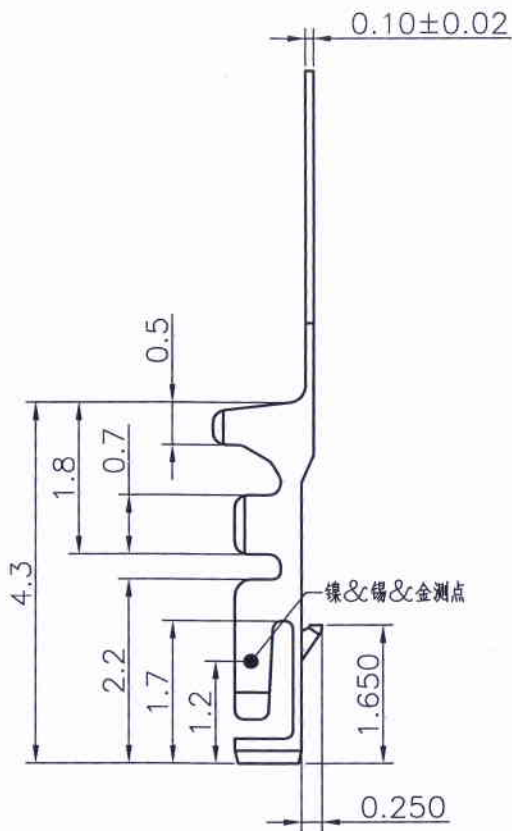
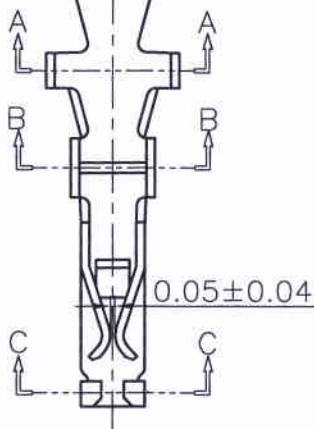
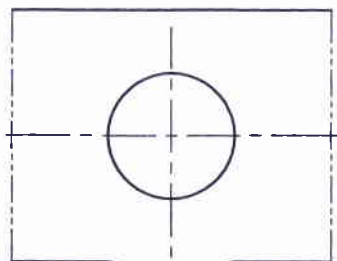
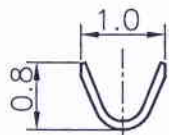

SECTION B-B

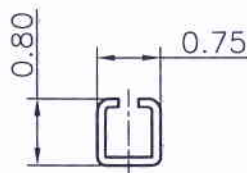

SECTION C-C

PART NO.
11005T1P-XX-S1-NK

Finish 0*--镀半金

0A--Gold-flash

0D--4u"

0G--15u"

Finish 5*--镀全金

5A--Gold-flash

5D--4u"

5G--15u"

0B--2u"

0E--5u"

0H--30u"

5B--2u"

5E--5u"

5H--30u"

0C--3u"

0F--10u"

0I--50u"

5C--3u"

5F--10u"

5I--50u"



Part No	Wire Range	Insulation O.D.	Material	Finish	Qty/reel
11005T1P-5X-S1-NK	AWG#32~#34	0.60mm(max)	Phosphor bronze	Gold-plated	20,000PCS
11005T1P-2E-S1-NK	AWG#32~#34	0.60mm(max)	Phosphor bronze	Tin-plated 60u"	20,000PCS
11005T1P-0X-S1-NK	AWG#32~#34	0.60mm(max)	Phosphor bronze	Gold-flash	20,000PCS

REV.	REVISION RECORD	DATE	GENERAL TOLERANCES	SCALE:	NAME	DATE	JCTC ® 胜蓝科技股份有限公司 TERMINAL&CONNECTORS 东莞市富智达电子科技有限公司	PART. NO:
A0	新图面发行	15. 03. 13	LINEAR	1:1				11005T1P-XX-S1-NK
A1	变更公司名称	17. 03. 27	ANGLES	APPROVED				DWG. NO:
			0.0±0.25	DESIGNER				ENDE05
			UNIT: MM	DRAWN			TITLE:	REV: A1
			SIZE: M1		卢小锋	17. 03. 27	88252 端子(低脚)	SHEET: 1/1
			0.00±0.15					
			0.000±0.08					