

Specifications:  
 Rated Voltage : 100V AC/DC  
 Rated Current : 2A AC,DC  
 Withstand Voltage : 800V AC/minute  
 Contact Resistance : 10mΩ(MAX.)  
 Insulation Resistance : 1000MΩ(MIN.)  
 Cap: Nylon 6T,UL94V-0 Natural(Black)  
 The product using material and processing must conform to the "WI-PZ-142"HSF technical standard control requirements

- 12001W00-2P-S-A-XX-HF-R  
 ① ② ③ ④ ⑤ ⑥ ⑦ ⑧
- ① Series No.
  - ② W90 : Side Contact  
W00 : Up Contact
  - ③ No. of Circuits
  - ④ S: SMT Type
  - ⑤ A: A Type
  - ⑥ XX: Finish
  - ⑦ HF: Halogen Free
  - ⑧ R: Tape & Reel(With Cap)



Part No.	Material	Color	PIN Material	Solder Tabs
12001W00-2P-S-A-R	Nylon 6T,UL94V-0	Natural(Beige)	Brass/Tin-plated	Brass/Tin-plated
12001W00-2P-S-A-5A-R	Nylon 6T,UL94V-0	Natural(Beige)	Brass/Gold flash	Brass/Tin-plated
12001W00-2P-S-A-5A-HF-R	LCP,UL94V-0	Natural(Beige)	Brass/Gold flash	Brass/Tin-plated

REV.	REVISION RECORD	DATE	UNIT: MM	SIZE: A4
C0	新图面发行	13. 12. 06		
C1	更新公司名称	17. 10. 10		
C2	WN2002280023	20. 02. 28		
C3	WN2003030026	20. 03. 03		

SCALE:	NAME	DATE	PART. NO.:	DWG. NO.:
1:1	张振坤	20.03.03	12001W00-2P-S-A	ENDE05
APPROVED:			TITLE:	
DESIGNER:			2.00mm PITCH WAFER-SMT TYPE	
DRAWN:	张振坤	20. 03. 03	大盖子	

**JCTC**®  
 TERMINAL&CONNECTORS

REV: C3 SHEET: 1/2

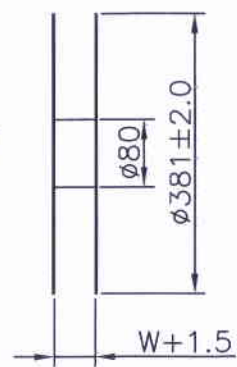
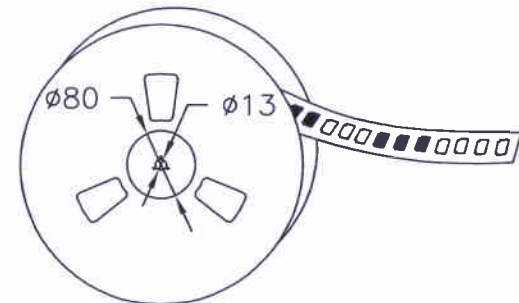
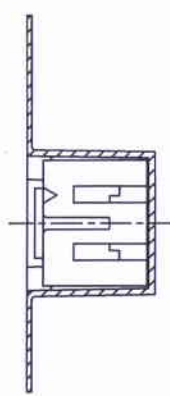
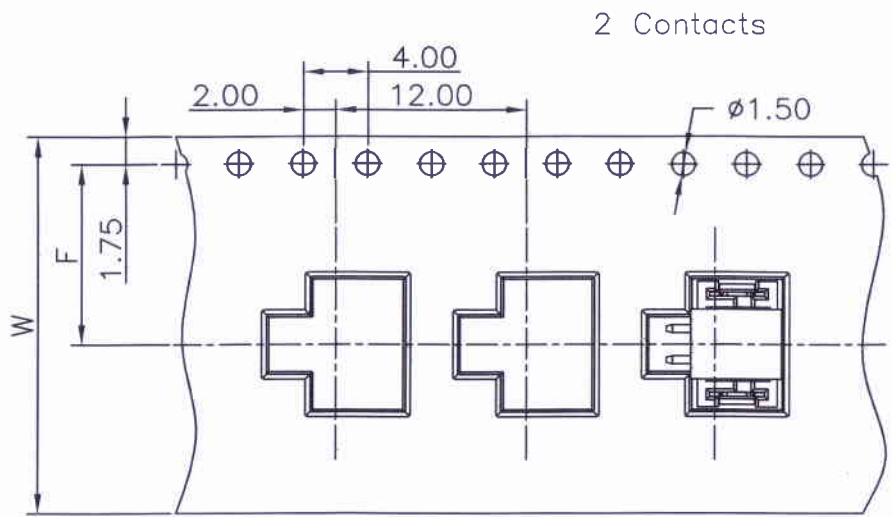

Unreeling direction

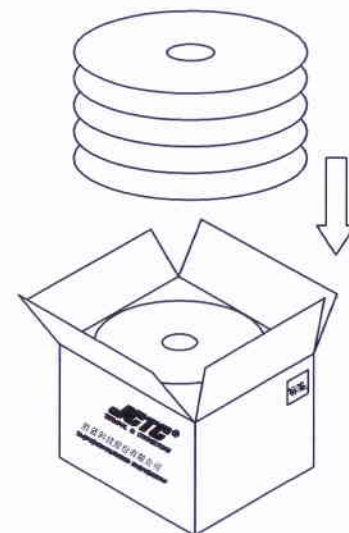
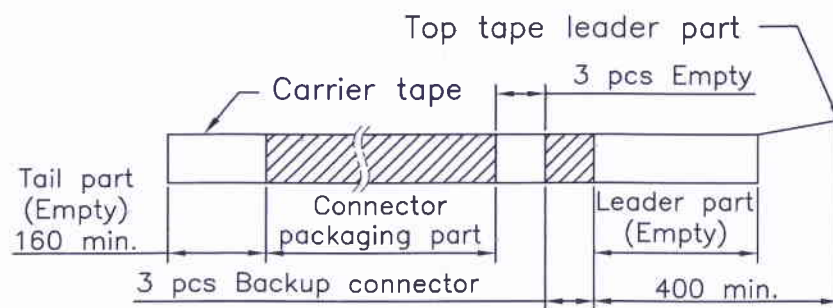
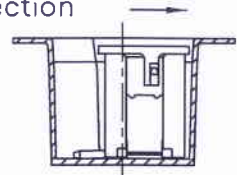

Load carton

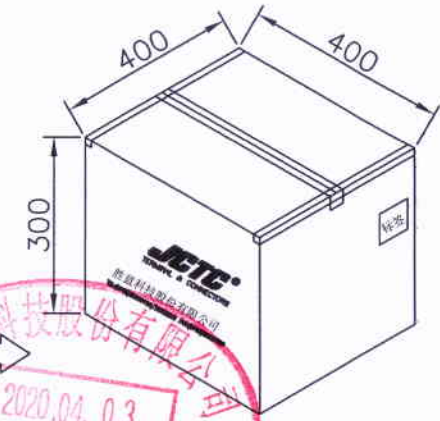

Sealed carton



Number of Contacts	W±0.3	F±0.1	S±0.1	Q'ty/Reel	Q'ty/Box
2P	24	11.50		1,000	10,000

REV.	REVISION RECORD	DATE	GENERAL TOLERANCES	SCALE:	NAME	DATE	PART. NO.:	DWG. NO.:
C0	新图面发行	13.12.06	LINEAR	1:1			12001W00-2P-S-A	ENDE05
C1	更新公司名称	17.10.10	0.0±0.25	APPROVED	张振坤	20.04.03		
C2	WN2003030026	20.03.03	0.00±0.15	DESIGNER	张振坤	20.04.03	TITLE:	
			0.000±0.08	DRAWN	张振坤	20.03.03	2.00mm PITCH WAFER-SMT TYPE	
			X° REF±6°				大盖子	
			X° ±3°					
			X° X'±2°					
			UNIT: MM					
			SIZE: A4					

**JCTC**®  
TERMINAL&CONNECTORS

REV: C2 SHEET: 2/2