

1 2 3 4 5 6 7 8

A  
B  
C  
D  
E  
F  
G  
H

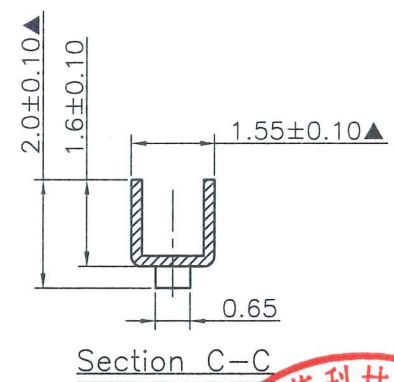

The product using material and processing must conform to the "WI-PZ-142-HSF" technical standard control requirements

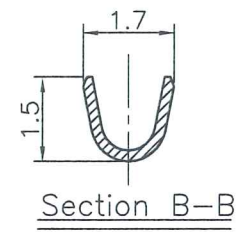
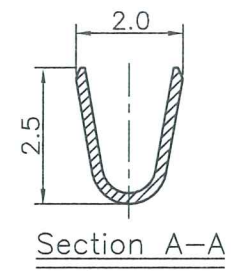
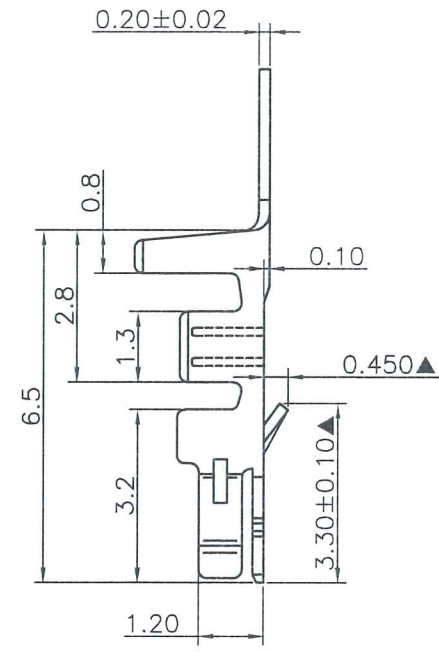
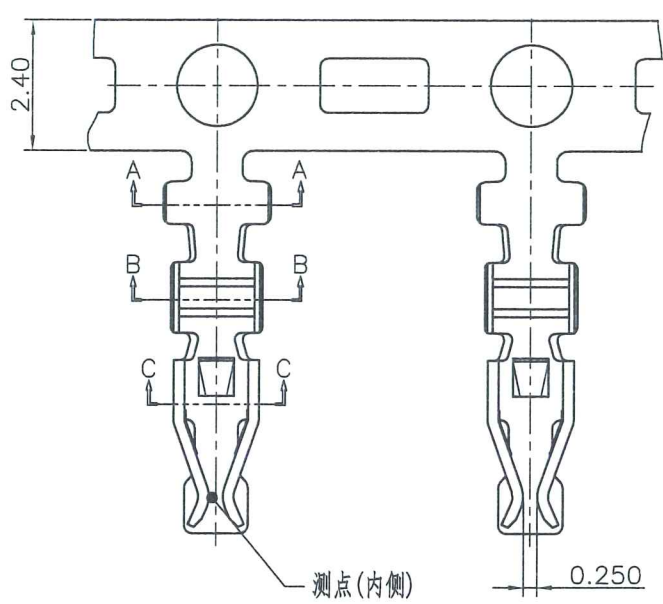

Part No	Wire Range	Insulation O.D.	Material	Finish	Qty/reel
12002TOP-OG-G-NK	AWG #24~#28	1.50mm(max)	Phosphor Bronze	Gold Plated 15u"on Contact Area,Ni Plated on all	1,0000 PCS

REV.	REVISION RECORD	DATE	UNIT: MM	GENERAL TOLERANCES		SCALE:	NAME	DATE	PART. NO:	DWG. NO:
AO	新图面发行	21.08.11		LINEAR	ANGLES	1:1	APPROVED			
			SIZE: A4	0.00±0.15	X° REF±6°		DESIGNER		12002TOP-XX-G-NK	ENDE05
			0.00±0.08	X° X'±2°		DRAWN				
									TITLE:	
									PHD2.0端子	

**JCTC**®  
TERMINAL&CONNECTORS

REV: AO SHEET: 1/1

1 2 3 4 5 6 7 8