

1 2 3 4 5 6 7 8

A B C D E F G H

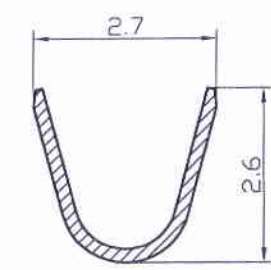

Section A-A

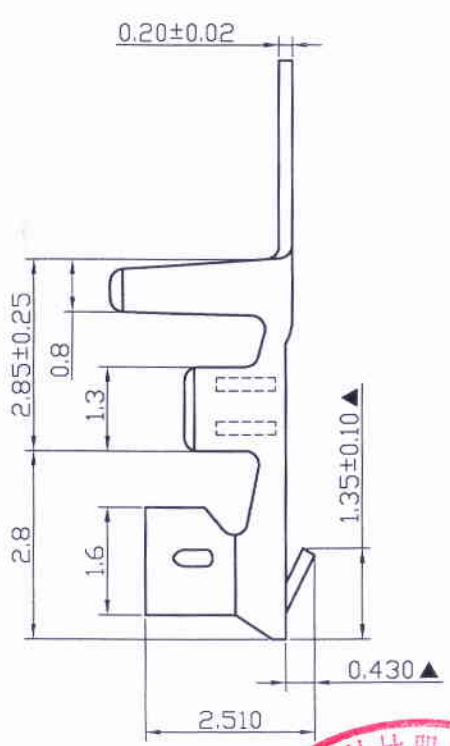
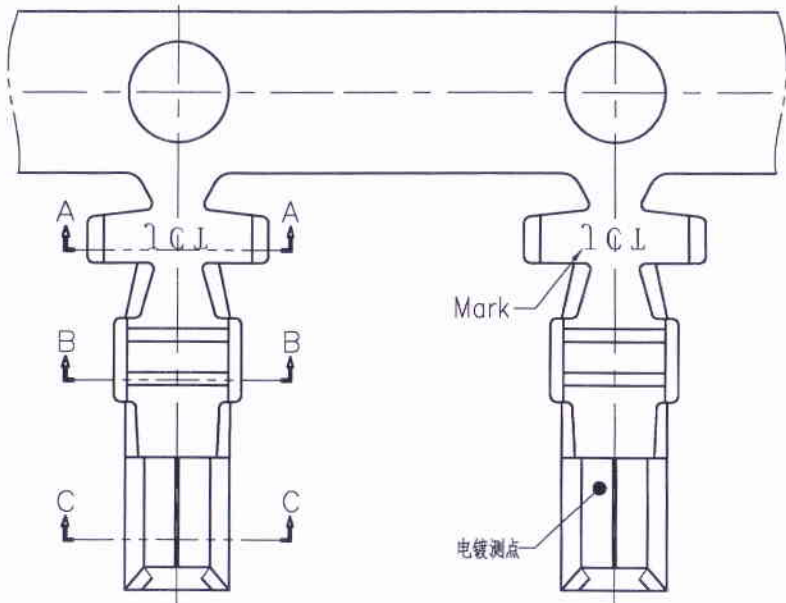
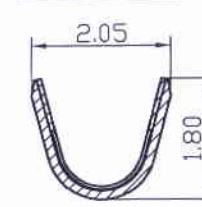

Section B-B

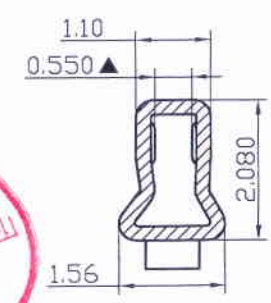

Section C-C

Note: 12502T2P-XX-XX
 Finish _____ Blank: With Mark
 NK: No Mark
 2E--Stamping after plating
 2--Plating after stamping
 5G--Au:15u" 5A--Au:1u"



The product using material and processing must conform to the "WI-PZ-142" HSF technical standard control requirements

Part No	Wire Range	Insulation O.D.	Material	Qty/reel
12502T2P-XX-XX	AWG #20~#24	1.90mm(max)	Phosphor Bronze	10,000 pcs

REV. A0	REVISION RECORD 新图面发行	DATE 20.03.19		GENERAL TOLERANCES		SCALE: 1:1	NAME	DATE	PART.NO: 12502T2P-XX-XX	DWG.NO: ENDE05	 TERMINAL&CONNECTORS	
				LINEAR	ANGLES	APPROVED						
				0.0±0.25	X° REF±6°	DESIGNER						
			UNIT: MM	0.00±0.15	X° ±3°	DRAWN	伍文聪	20.03.19	TITLE: EH2.5 高脚端子		REV: A0	SHEET: 1/1
			SIZE: A4	0.000±0.08	X° X'±2°							

1 2 3 4 5 6 7 8

A B C D E F G H