

RoHS

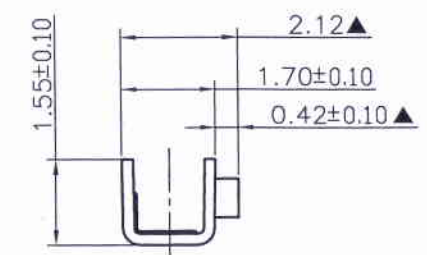

Section A-A

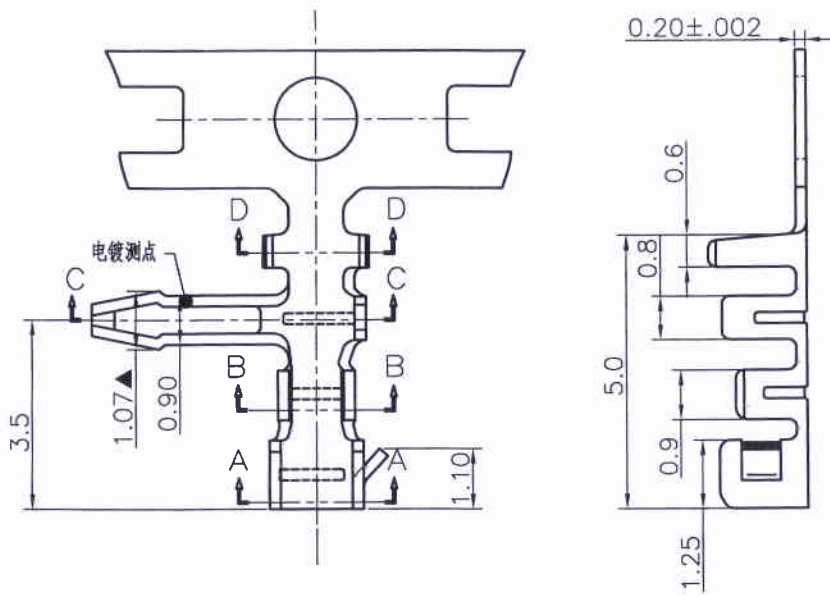
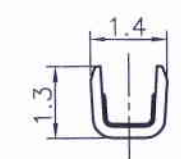
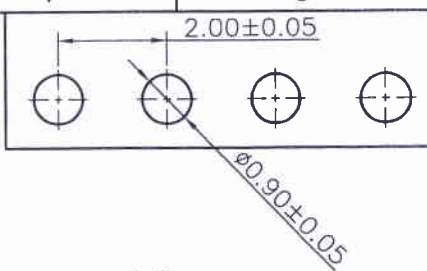

Section B-B

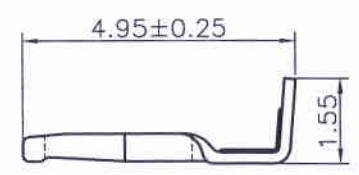

Section C-C

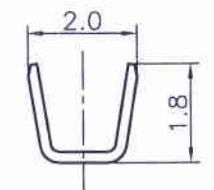

Section D-D

Part No	Wire Range	Insulation O.D.	Material	Finish	Qty/reel
22001T9B-2E-D-NK	AWG #24~#28	1.45mm(max)	Brass	Tin-plated 60u"Min	10,000 pcs

22001T9 B- 2E-D- NK  
 Series ————  
 Material ————  
 B:Brass  
 Type ————  
 Plating ————  
 2E: Tin-plated (Stamping before plating)  
 Space:Mark  
 NK:No Mark



REV.	REVISION RECORD	DATE	GENERAL TOLERANCES	SCALE:	NAME	DATE	JCTC® 胜蓝科技股份有限公司 TERMINAL&CONNECTORS 东莞市富智达电子科技有限公司	PART. NO:
C0	新图面发行	10.01.18	LINEAR	1:1	APPROVED			
C1	TN1011260139	10.11.26	0.0±0.25		DESIGNER			DWG. NO:
C2	TN1103240048	11.03.24	0.00±0.15		DRAWN			ENDE05
C3	变更公司名称	17.05.10	0.000±0.08					REV: C3 SHEET: 1/1

TITLE: SAN2.0 90° 端子