

RoHS

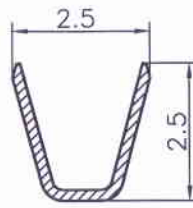

SECTION A-A

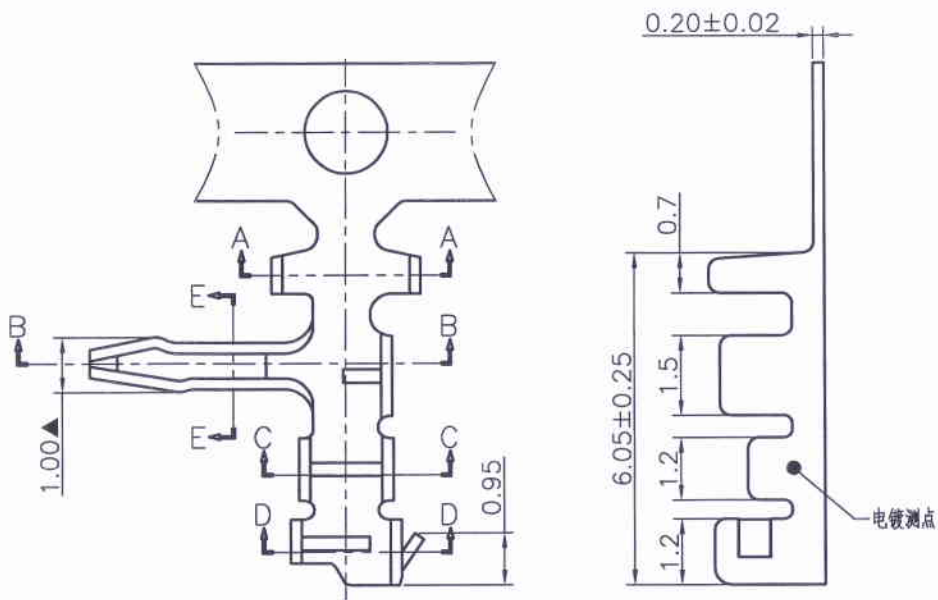
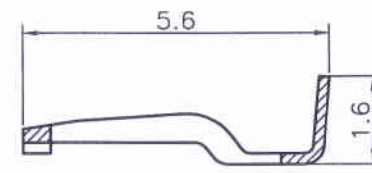

SECTION B-B

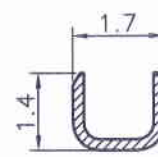

SECTION C-C

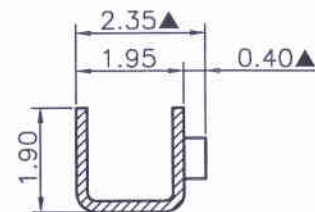

SECTION D-D

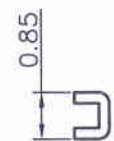

SECTION E-E

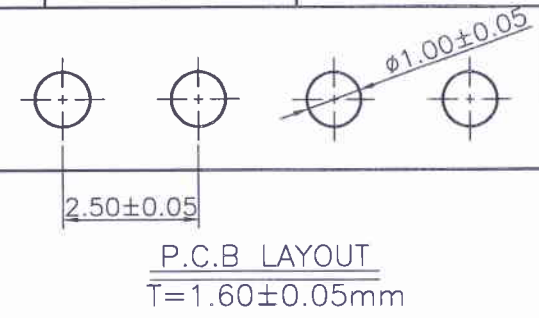

Specification & Ordering Information:

Part No	Wire Range	Insulation O.D.	Material	Finish	Qty/reel
22501T9P-2-NK	AWG #22~#26	1.60mm(max)	phosphor bronze	Tin-plated	7,000 pcs

REV.	REVISION RECORD	DATE	GENERAL TOLERANCES	SCALE:	NAME	DATE	JCTC® 胜蓝科技股份有限公司 TERMINAL&CONNECTORS 东莞市富智达电子科技有限公司	PART. NO:	
CO	新图面发行	12.07.02	LINEAR	1:1	APPROVED			22501T9P-2-NK	
C1	更新公司名称	17.03.18	0.0±0.25	X° REF±6°	DESIGNER	17.03.18	DWG. NO:		
			UNIT: MM	0.00±0.15	X° ±3°	DRAWN	伍文聪	17.03.18	TITLE:
			SIZE: A4	0.000±0.08	X° X'±2°				SCN2.5 90° 端子
									REV: C1 SHEET: 1/1