

RoHS

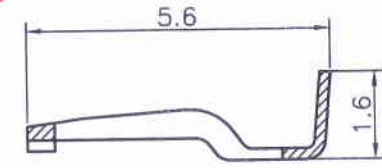

SECTION B-B

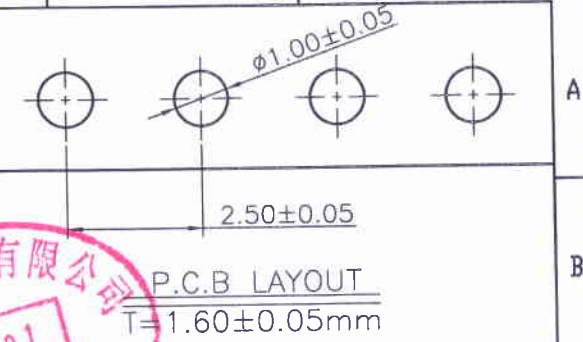
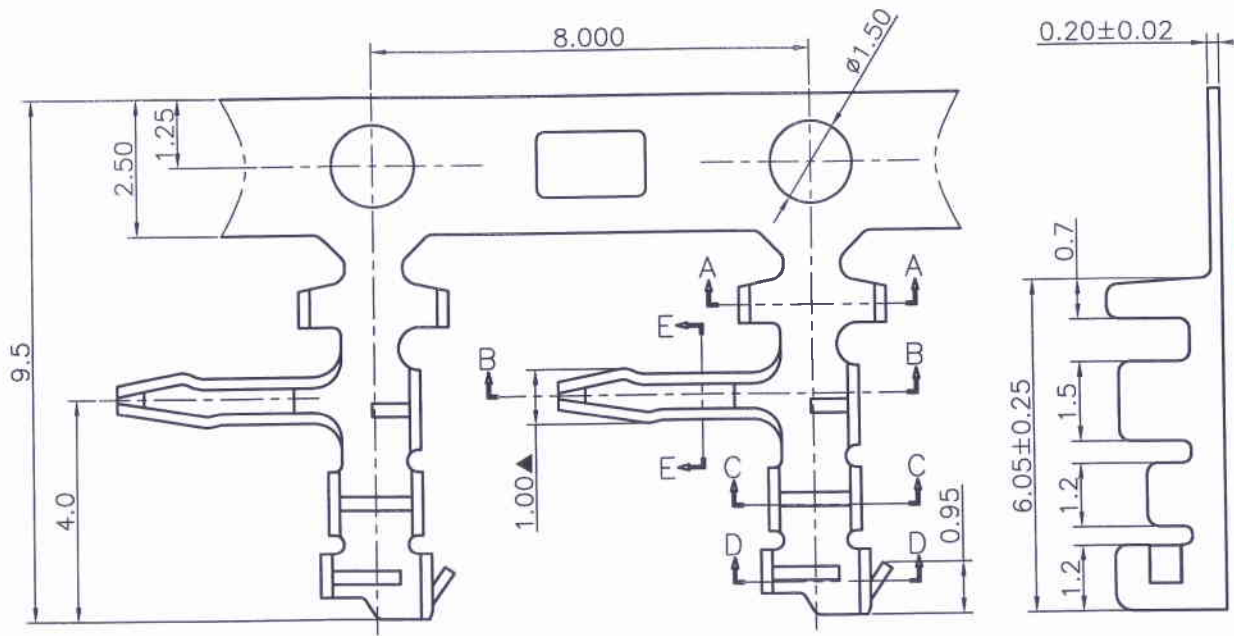
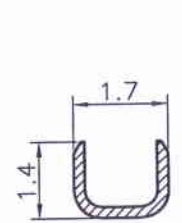

SECTION C-C

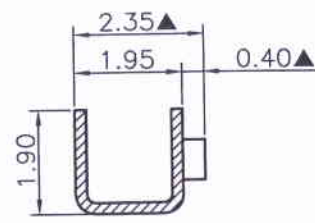

SECTION D-D

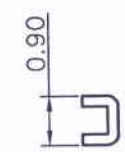

SECTION E-E

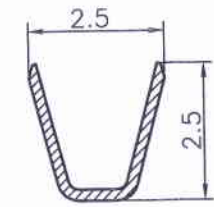

SECTION A-A

Specification & Ordering Information:

Part No	Wire Range	Insulation O.D.	Material	Finish	Qty/reel
22501T9P-3E-NK	AWG #22~#28	1.60mm(max)	phosphor bronze	Matte Tin-plated 100u'Min.	7,000 pcs

REV.	REVISION RECORD	DATE	GENERAL TOLERANCES	SCALE:	NAME	DATE	JCTC® 胜蓝科技股份有限公司 TERMINAL&CONNECTORS 东莞市富智达电子科技有限公司	PART. NO:
C0	新图面发行	12.08.17	LINEAR	1:1	APPROVED			
C1	更新公司名称	17.03.18	0.0 ± 0.25		DESIGNER	17.03.18		DWG. NO:
			0.00 ± 0.15		DRAWN	伍文聪		ENDE05
			0.000 ± 0.08					REV: C1 SHEET: 1/1

TITLE: SCN2.5 90° 端子