

RoHS

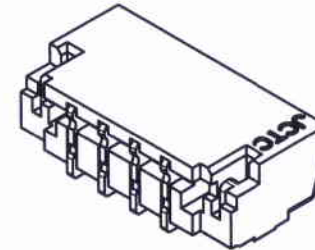

P.C.B. LAYOUT

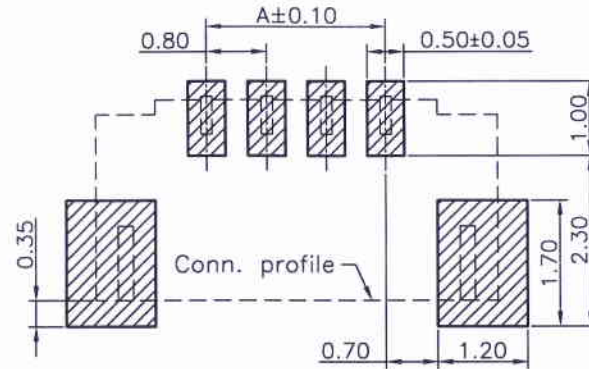
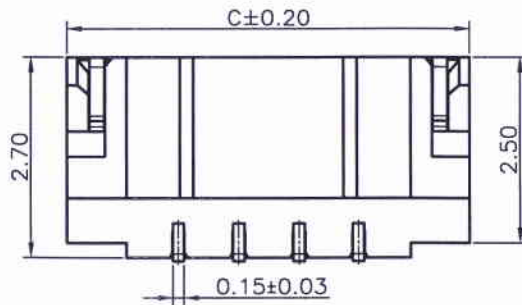
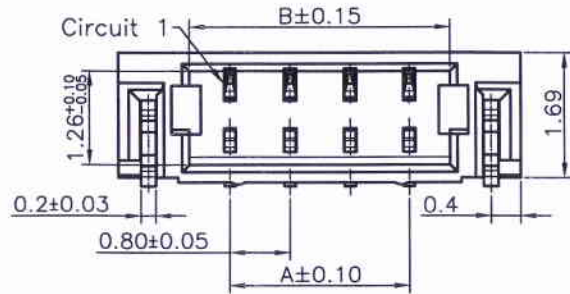

50801W90-NPX-S-HF-01  
① ② ③④⑤⑥ ⑦

- ① Series No.
- ② W90 : Side Contact  
W00 : Up Contact
- ③ No. of Circuits
- ④ A : Product color(A--Y)  
Blank : Natural type
- ⑤ S: SMT Type
- ⑥ HF : Halogen Free
- ⑦ 01 : 01 Type

Specifications:  
Rated Voltage : 30V AC/DC  
Rated Current : 0.5A AC,DC  
Withstand Voltage : 200V AC/minute  
Contact Resistance : 30mΩ(MAX.)  
Insulation Resistance : 100MΩ(MIN.)  
Temperature Range : -25°C~+85°C

Dimensional Ordering Information:			
Circuits Part No	Dimensions		
	A	B	C
2P	1.60	1.90	3.80
3P	2.40	2.70	4.60
4P	3.20	3.50	5.40
5P	4.00	4.30	6.20
6P	4.80	5.10	7.00
7P	5.60	5.90	7.80
8P	6.40	6.70	8.60
9P	7.20	7.50	9.40
10P	8.00	8.30	10.20
11P	8.80	9.10	11.00
12P	9.60	9.90	11.80
13P	10.40	10.70	12.60
14P	11.20	11.50	13.40
15P	12.00	12.30	14.20
16P	12.80	13.10	15.00
17P	13.60	13.90	15.80
18P	14.40	14.70	16.60
19P	15.20	15.50	17.40
20P	16.00	16.30	18.20
21P	16.80	17.10	19.00
22P	17.60	17.90	19.80
23P	18.40	18.70	20.60
24P	19.20	19.50	21.40

Part No.	Material	Color	Pin Material	Solder Tabs
50801W90-NP-S-HF-01	High temperature plastic,UL94V-0	黑/Beige	Phosphor Bronze/Matte Tin-plated	Brass/Matte Tin-plated
50801W90-NP-S-HF-NK-01	High temperature plastic,UL94V-0	黑/Beige	Phosphor Bronze/Matte Tin-plated	Brass/Matte Tin-plated

REV.	REVISION RECORD	DATE	GENERAL TOLERANCES		SCALE:	NAME	DATE	<b>JCTC</b> 胜蓝科技股份有限公司 TERMINAL&CONNECTORS 东莞市富智达电子科技有限公司	PART. NO:
C0	换图框发行	12. 11. 29	LINEAR	ANGLES	1:1	APPROVED			50801W90-NP-S-HF-XX-01
C1	新增不印字规格	13. 02. 26	0.0±0.25	X° REF±6°	DESIGNER				DWG. NO:
C2	变更公司名称	17. 03. 20	UNIT: MM SIZE: A4	0.00±0.15 X° X'±2°	DRAWN	卢小锋	17. 03. 20		ENDE05
								TITLE:	REV: C2 SHEET: 1/2

0.8刺破 90° WAFER CONN

RoHS

02~17 Contacts

18~24 Contacts

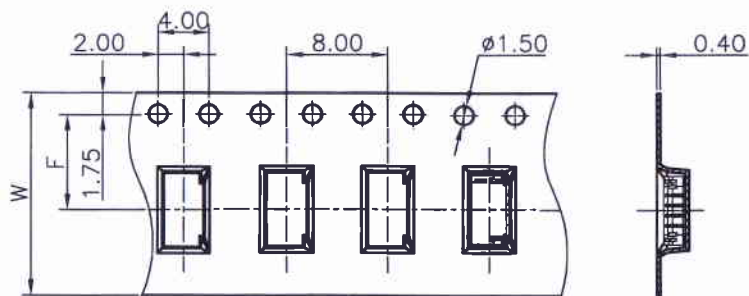

Unreeing direction →

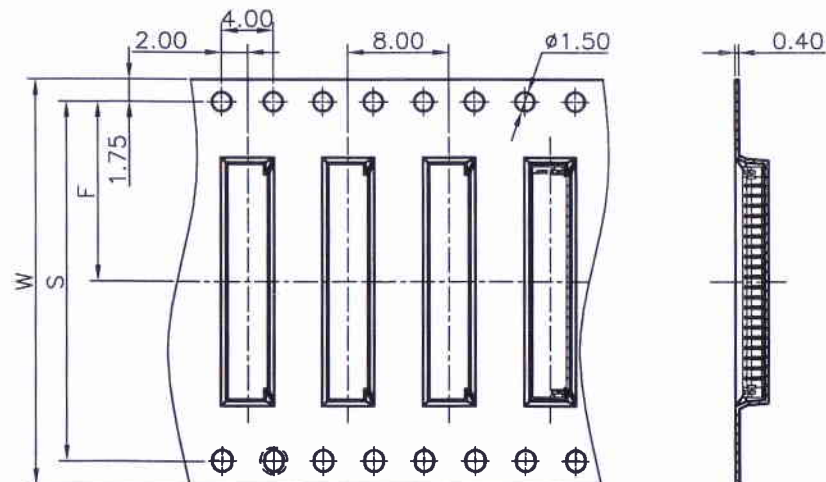
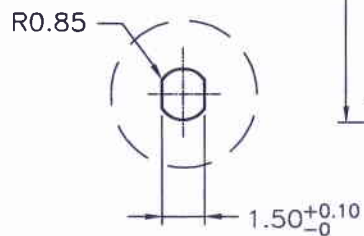

Unreeing direction →

Number of Contacts	W±0.3	F±0.1	S±0.1	Q'ty/Reel
2P	16	7.50		3,500
3P	16	7.50		3,500
4P	16	7.50		3,500
5P	16	7.50		3,500
6P	16	7.50		3,500
7P	16	7.50		3,500
8P	24	11.50		3,500
9P	24	11.50		3,500
10P	24	11.50		3,500
11P	24	11.50		3,500
12P	24	11.50		3,500
13P	24	11.50		3,500
14P	24	11.50		3,500
15P	24	11.50		3,500
16P	24	11.50		3,500
17P	24	11.50		3,500
18P	32	14.20	28.40	3,500
19P	32	14.20	28.40	3,500
20P	32	14.20	28.40	3,500
21P	32	14.20	28.40	3,500
22P	32	14.20	28.40	3,500
23P	32	14.20	28.40	3,500
24P	32	14.20	28.40	3,500

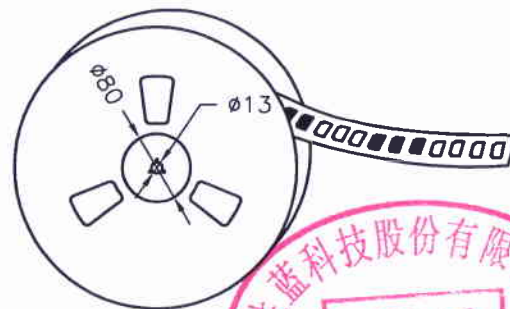
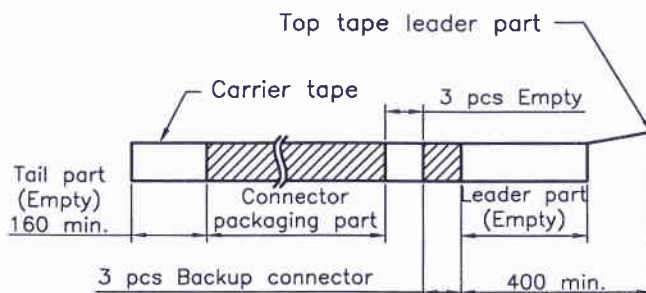

胜蓝科技股份有限公司  
2017.03.23  
工程部部长  
技术文件发行章

NOTE:  
Material: Transparent  
Anti-static Polystyrene.

REV.	REVISION RECORD	DATE	GENERAL TOLERANCES	SCALE:	NAME	DATE	PART. NO:
C0	新图面发行	10.06.05	LINEAR	1:1			50801W90-NP-S-HF-XX-01
C1	变更公司名称	17.03.20	0.0 ± 0.25	APPROVED			DWG. NO: ENDE05
			0.00 ± 0.15	DESIGNER	卢小锋	17.03.20	REV: C1 SHEET: 2/2
			0.000 ± 0.08	DRAWN	卢小锋	17.03.20	TITLE: 0.8刺破 90° WAFER CONN

JCTC® 胜蓝科技股份有限公司  
TERMINAL&CONNECTORS 东莞市富智达电子科技有限公司