

# 环保物料

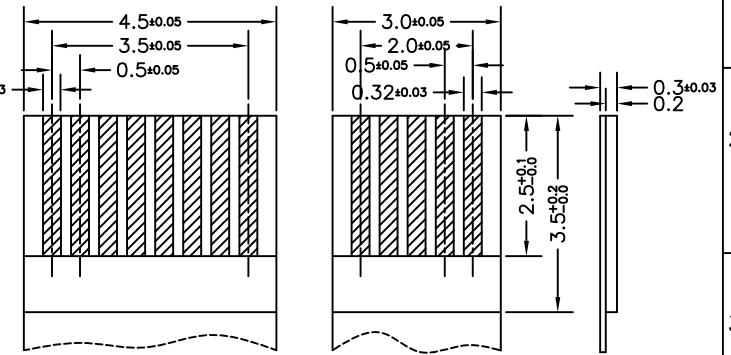

## APPLICABLE FFC

Voltage Rating : 50V AC/DC  
 Current Rating : 0.5A AC,DC  
 Withstand Voltage : 500V AC/minute  
 Contact Resistance : 30mΩ(MAX.)  
 Insulation Resistance : 100MΩ(MIN.)  
 Temperature Range : -25°C~+85°C  
 ▲"to focus on the inspection size,  
 sampling every three hours.

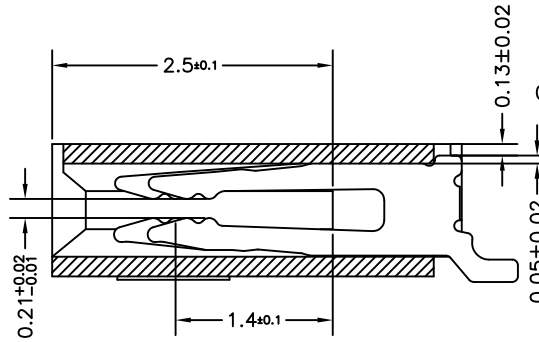
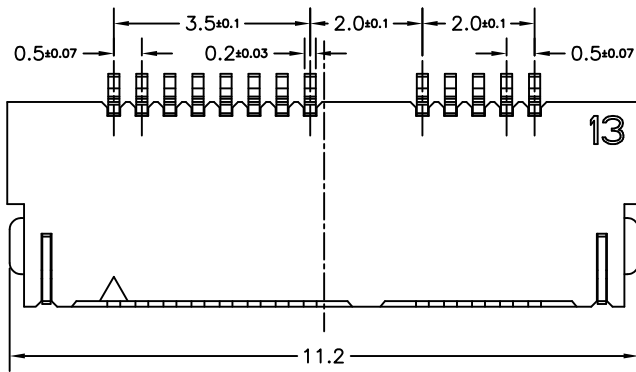
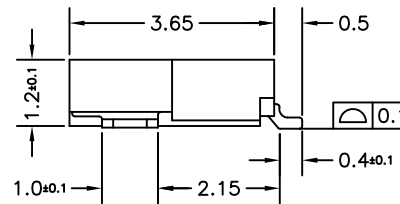
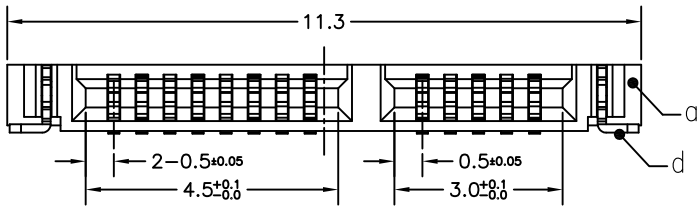

40562W90-NPN-S H L OA T C R

① ② ③④⑤⑥⑦⑧⑨⑩⑪

- ① Series No.
- ② W90 :Right angle
- ③ No. of Circuits 13=13Pin
- ④ Color: N=Natural
- ⑤ S: SMT type
- ⑥ H=Halogen Free
- ⑦ Material: L=LCP
- ⑧ Plating for contacts:  
OA=Gold-flash on contact area
- ⑨ Plating for solder area:  
T=Tin Plating (LEG)
- ⑩ Assembly Style  
C=Turned up actuator the back
- ⑪ R=Tape & Reel

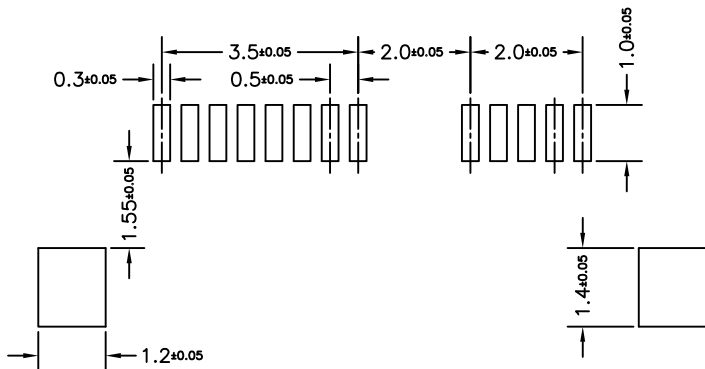

## P.C.B LAYOUT REF

No.	Description	Material	Color/Finish
a	Housing	LCP,UL94V-0	Natural
c	Terminal	Phosphor Bronze	See notes
d	LEG	Brass	Matte Tin Plating Over Ni

一般公差 GENERAL TOLERANCE					绘图 DR.	料号 PART NO.		文件编号 NUMBER		 TERMINAL&CONNECTORS		
X.X	±0.15	X*	±2*	校对 CHK.	40562W90-13PN-SHLOATCR		ENDPT01					
X.XX	±0.05	X.X*	±1*	审核 CHK.	品名 TITLE		FPC 0.5 Pitch 1.2H NIF R/A Connector		比例 SCALE	SHEET	版次 REV.	
X.XXX	±0.02	▲ MAJOR DIM.		核准 APPD.	程功银		李兴泽		1/1	1/2	A1	
A1	20.08.21	更新图框发行	李兴泽	杨章雄	程功银	料号 PART NO.		文件编号 NUMBER		 TERMINAL&CONNECTORS		
A0	17.01.19	新图框发行	李兴泽	杨章雄	李兴泽	品名 TITLE		FPC 0.5 Pitch 1.2H NIF R/A Connector				
版次 REV.	日期 DATE	变更内容 DESCRIPTION	审核 CHK.	核准 APPD.	杨章雄	料号 PART NO.		文件编号 NUMBER		1/1	1/2	A1

