

Current Rating : 0.5A AC,DC
 Voltage Rating : 50V AC/DC
 Withstand Voltage : 250V AC/minute
 Contact Resistance : 30mΩ(MAX.)
 Insulation Resistance : 100MΩ(MIN.)
 Temperature Range : -25°C~+85°C

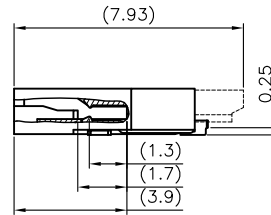

SECTION A-A
SCALE 1:1

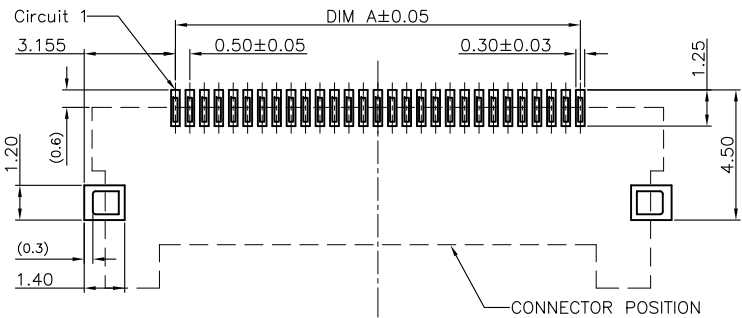
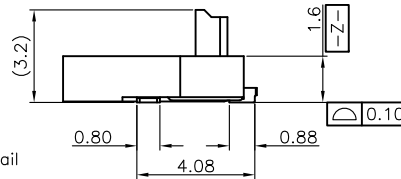
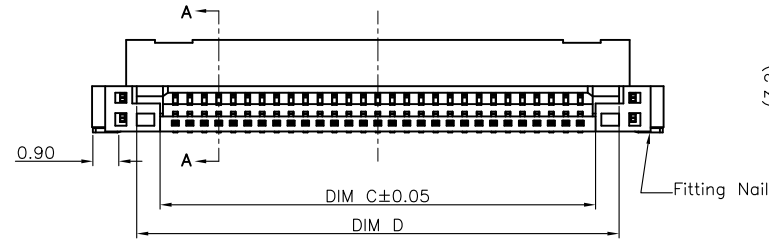

RECOMMENDED P.C.B. PATTERN LAYOUT

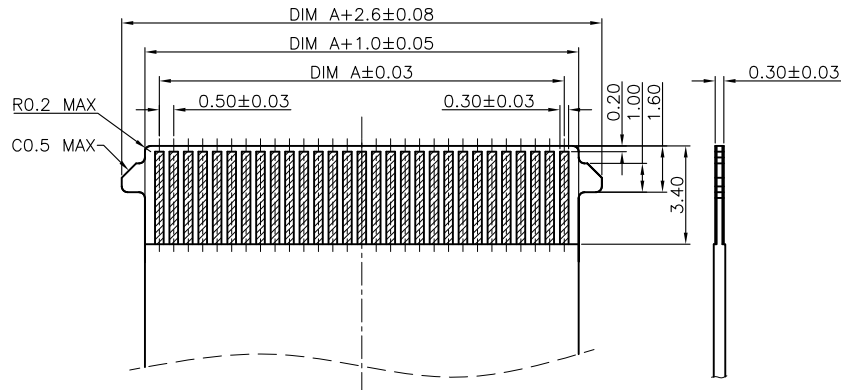

RECOMMENDED FPC/FFC DIMENSION

40587W90-NPA2-S H L XX T C R

- ① Series No.
- ② W90 :Right angle
- ③ No. of Circuits
- ④ Color: A=Black&0.3mm FFC线
- ⑤ S: SMT type
- ⑥ H=Halogen Free
- ⑦ Material: L=LCP
- ⑧ Plating for contacts:
 OA=Plating Gold 0.4u" Min contact area
 5A=OA=Plating Gold 5u" contact area
- ⑨ Plating for solder area(LEG):
 T=Tin Plating
- ⑩ Assembly Style
 C=Turned up actuator the back
- ⑪ R=Tape & Reel

PIN NO.	DIM A	DIM B	DIM C	DIM D	DIM E
42PIN	20.50	26.21	21.56	23.18	26.26

版次REV.	日期 DATE	变更内容 DESCRIPTION	审核 CHK.	核准 APPD.
A2	20.08.26	更新图框发行	李兴泽	杨章雄
A1	18.03.06	更新图面发行	李兴泽	杨章雄
A0	17.05.26	新图面发行	李兴泽	杨章雄

一般公差 GENERAL TOLERANCE	
X.X ±0.15	X* ±2*
X.XX ±0.10	X.X* ±1*
X.XXX ±0.05	▲ MAJOR DIM.
单位 UNIT	mm

绘图 DR.	程功银
校对 CHK.	李兴泽
审核 CHK.	李兴泽
核准 APPD.	杨章雄

料号 PART NO.	文件编号 NUMBER
40587W90-42PA2-SHLxxTCR	ENDPT01
品名 TITLE	
0.5Pitch H=1.6 FPC CONN 2	

JGTC® TERMINAL&CONNECTORS		
比例 SCALE	SHEET	版次 REV.
1/1	1/1	A2

环保物料

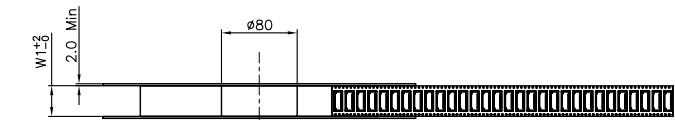

- NOTES:
- 1.10 SPROCKET HOLE PITCH CUMULATIVE TOLERANCE.±0.20mm
 - 2.CARRIER CAMBER NOT TO EXCEED 1mm IN 250mm.
 - 3.ALL DIMENSIONS MEET EIA-481-D REQUIREMENTS.
 - 4.MATERIAL: BLACK ANTI-STATIC POLYSTYRENE.
 - 5.THICKNESS: 0.30 ± 0.05 mm.
 - 6.PACKING LENGTH PER 15" REEL: 24.60METERS.
 - 7.COMPONENT LOAD PER 15" REEL: 1500PCS
 - 8.PEELING OFF FORCE OF TOP TAPE 0.1N~0.7N(10.2gf~71.4gf).

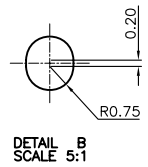
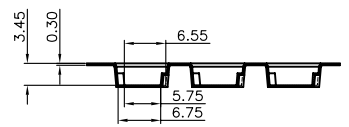
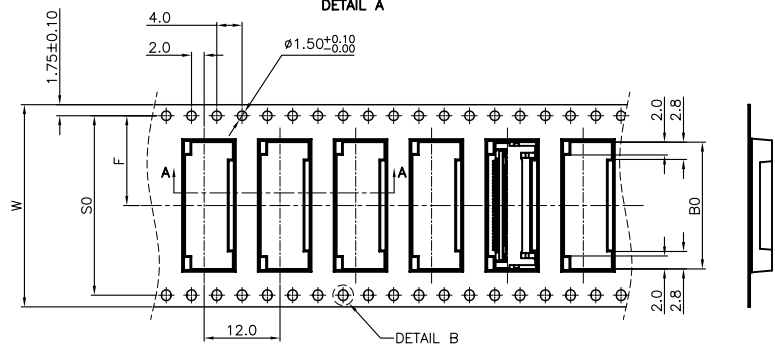
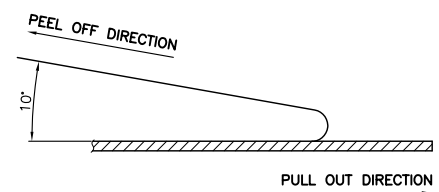
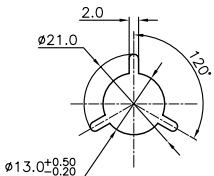
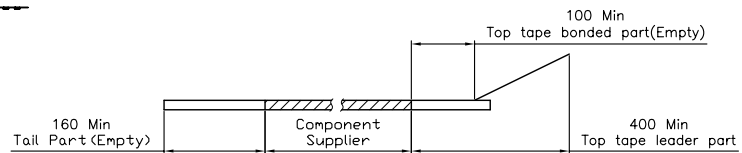
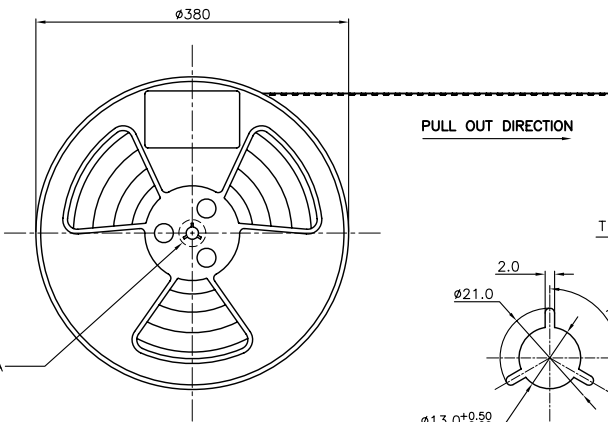

CKTS	B0±0.10	W	W1	F	S0±0.10
42	26.56	44±0.30	44.4	20.2±0.15	40.4

8	A2	20.08.26	更新图框发行	李兴泽	杨章雄	一般公差 GENERAL TOLERANCE X.X ±0.30 X' ±2' X.XX ±0.20 X.X' ±1' X.XXX ±0.10 ▲ MAJOR DIM.	绘图 DR. 李兴泽 校对 CHK. 杨章雄 审核 CHK. 核准 APPD.	料号 PART NO. 40587W90-NPA2-SHLXTCR		文件编号 NUMBER ENDPT01		 TERMINAL&CONNECTORS
	A1	19.06.28	更新载带盘规格发行	李兴泽	杨章雄			品名 TITLE		0.5Pitch H=1.6 FPC 后压卧式2代SMT型	比例 SCALE 1/1	
	A0	17.02.23	换图框发行	李兴泽	杨章雄	单位 UNIT mm						
	版次 REV.	日期 DATE	变更内容 DESCRIPTION	审核 CHK.	核准 APPD.							