

RoHS

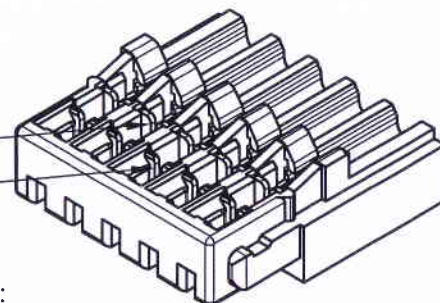

SEC: A-A  
SCALE: 2.5:1

Specifications:  
Rated Voltage : 30V AC/DC  
Rated Current : 0.5A AC,DC  
Withstand Voltage : 200V AC/minute  
Contact Resistance : 30mΩ(MAX.)  
Insulation Resistance : 100MΩ(MIN.)  
Temperature Range : -25°C~+85°C

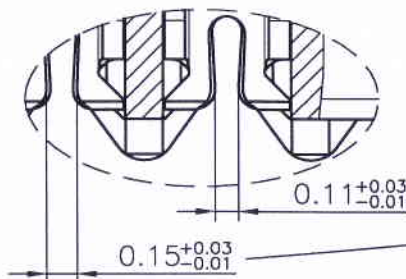
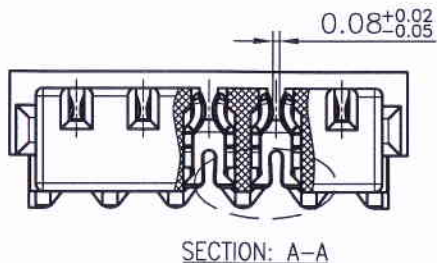
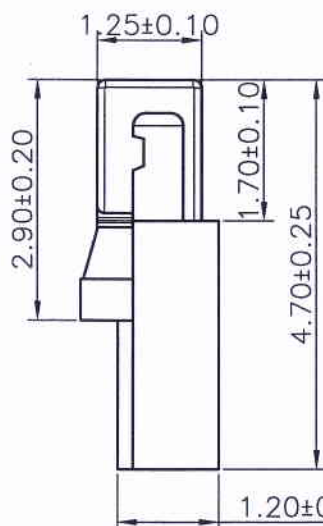
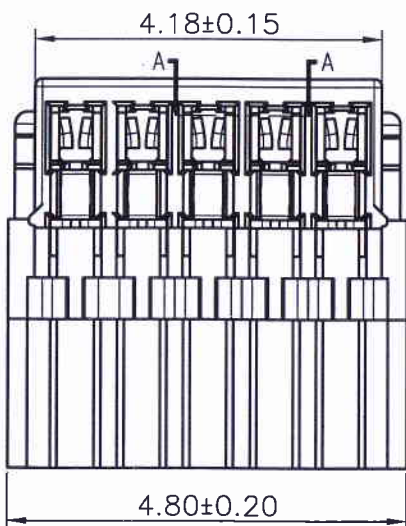

50801H00-5PX-S2-001

① ② ③④ ⑤ ⑥

- ① Series No.
- ② H90 : Side Contact  
H00 : Up Contact
- ③ No. of Circuits
- ④ X : Product color(A--Y)  
Blank: Natural type
- ⑤ S2 : S2 Type
- ⑥ 001 : Terminal/Gold-flash & Halogen Free & AWG #32

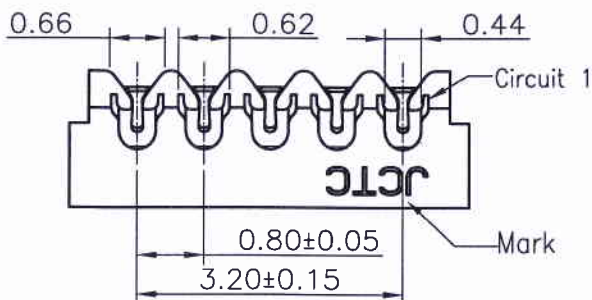

Applicable Wire: AWG #32(Insulation O.D.: 0.38mm)

| Part No.            | Material         | Color          | Terminal Material          |
|---------------------|------------------|----------------|----------------------------|
| 50801H00-5P-S2-001  | Nylon 66,UL94V-0 | Natural(White) | Phosphor Bronze/Gold-flash |
| 50801H00-5PA-S2-001 | Nylon 66,UL94V-0 | Black          | Phosphor Bronze/Gold-flash |

| REV. | REVISION RECORD | DATE       | GENERAL TOLERANCES | SCALE:   | NAME | DATE       | PART. NO:<br>50801H00-5PX-S2-001 |
|------|-----------------|------------|--------------------|----------|------|------------|----------------------------------|
| C0   | 换图框发行           | 10. 11. 18 | LINER              | 1:1      |      |            |                                  |
| C1   | HN1108150121    | 11. 08. 15 | ANGLES             | APPROVED |      |            |                                  |
| C2   | HN1111010145    | 11. 11. 01 | 0.0±0.25 X° REF±6° | DESIGNER |      |            | REV: C3 SHEET: 1/1               |
| C3   | 变更公司名称          | 17. 03. 20 | 0.00±0.15 X° ±3°   | DRAWN    | 卢小锋  | 17. 03. 20 |                                  |

**JCTC** 胜蓝科技股份有限公司  
TERMINAL&CONNECTORS 东莞市富智达电子科技有限公司

TITLE:  
JST0.8刺破加高型 0.80mm PITCH HOUSING