

1 2 3 4 5 6 7 8

A  
B  
C  
D  
E  
F  
G

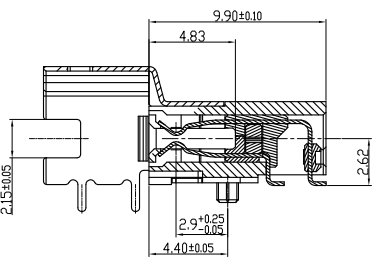
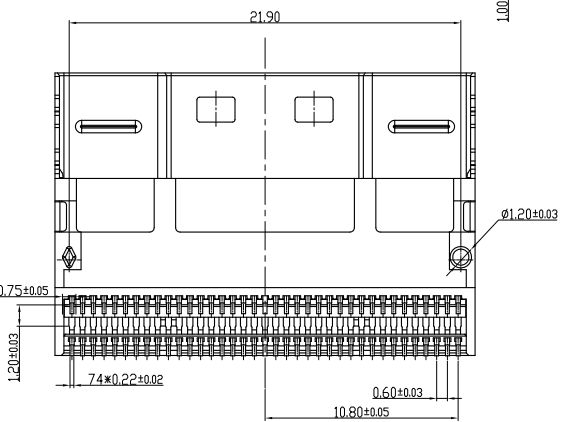
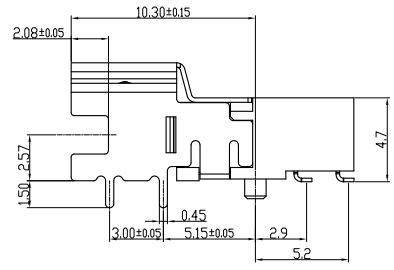
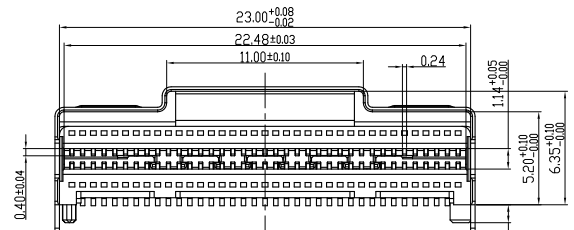
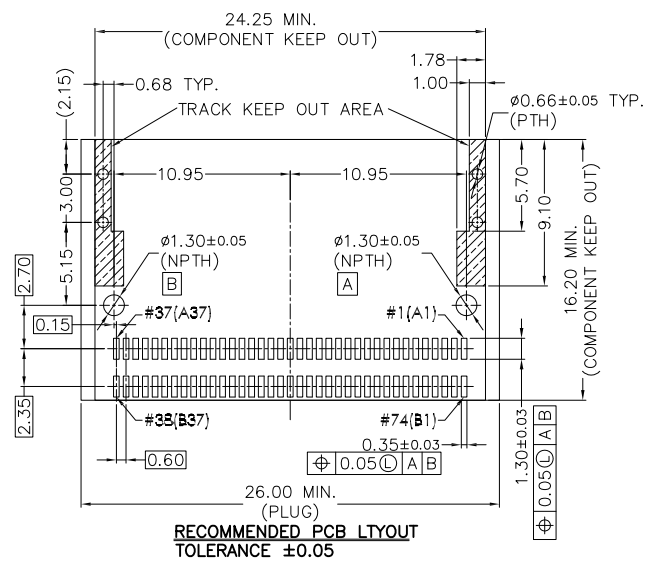
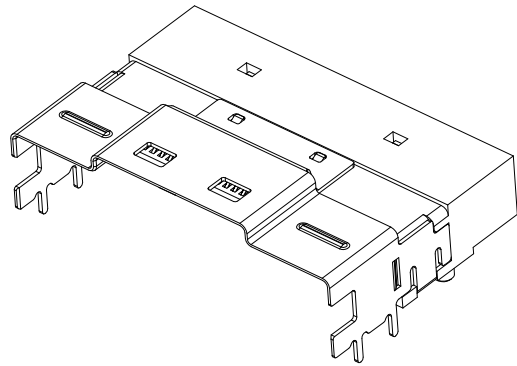
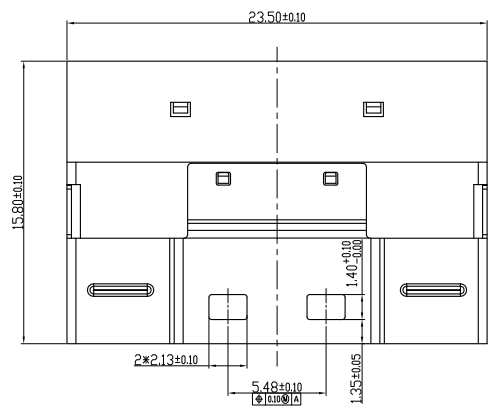

NOTES:  
1. MATERIAL:  
HOUSING: SOLDER REFLOW PROCESS COMPATIBLE LCP,BLACK,UL 94V-0  
CONTACTS: HIGH PERFORMANCE COPPER ALLOY, PLATING REFER TO P/N SYSTEM  
LATCH: STAINLESS STEEL, SOLDERABLE NICKEL OVERALL  
2. RoHS COMPLIANT  
3. P/N ORDER

8-0601W-1-0-2X74P-A-S-F-002  
SLIMSAS SERIAL 002: PLPELINED CODE  
P/DUCT PITCH 1001;1.00mm pitch #1 Type; F: WITH LOCATING POST  
0601;0.60mm pitch #1 Type; S: SMT TYPE  
HSG COLOR: A: BLACK  
CONTACT NUMBER: 74P: 74PIN CONTACT  
2X: DOUBLE ROW CONTACT  
3X: THREE ROW CONTACT  
H:HOUSE  
W:ASSEMBLY PRODUCT  
0: 180° 1: 90°  
D: UL94V-0;  
1:UL94V-1;

REV.	REVISION RECORD	DATE		GENERAL TOLERANCES		SCALE: 1:1	NAME	DATE	PART. NO: 80601W10-2X74PA-SF-002	DWG. NO: ENDE05	 TERMINAL&CONNECTORS
A0	新图面发行	2019. 11. 23		LINEAR	ANGLES	APPROVED					
			UNIT: MM	0.00±0.20	X° ±3°	DESIGNER		TITLE:			
			SIZE: A4	0.000±0.10	X° X'±2°	DRAWN	Wang_jr	2019. 11. 23	SLIMSAS X8_SOCKET R/A	REV: A0	SHEET: 1/1

1 2 3 4 5 6 7 8

A  
B  
C  
D  
E  
F  
G  
H