

The product using material and processing must conform to the "WL-PZ-001"HSF technical standard control requirements

RoHS+HF

NOTES:
 1. MATERIAL:SEE TABLE
 2. FINISH:
 2.1 TERMINAL:UNDER PLATING:NICKEL 2.0 μ mMIN.,CONTACT AREA:GOLD 0.25 μ mMIN.,
 SOLDER AREA:MATTE TIN 1.0 μ mMIN
 2.2 SHELL: 2.5 μ mMIN. NICKEL PLATING OVER ALL.
 2.3 HOOK: UNDER PLATING:NICKEL 2.5 μ mMIN. MATTE TIN 1.0 μ mMIN OVER ALL.
 3.P/N: WL DB M 9-XX 1 1 A 0 171

CONNECTOR:
 DB-D-SUB
 MALE FEMALE:
 M-MALE
 ANGLE:
 9-90°
 PIN Q'PY:
 26/50PIN
 COLOR:
 A-BLACK
 PLATING:
 1-G/F
 2-AU 3U"
 9-Ni
 TERMIPOINT:
 1-DIP

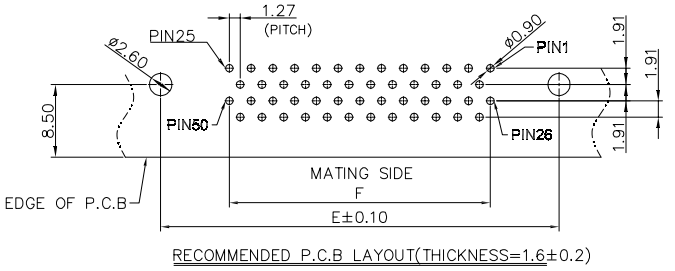
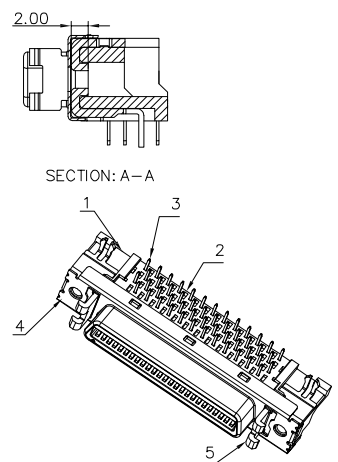
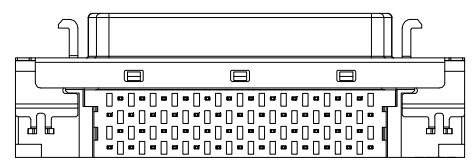
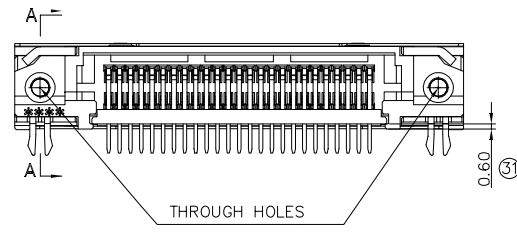
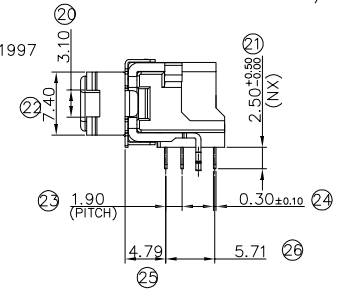
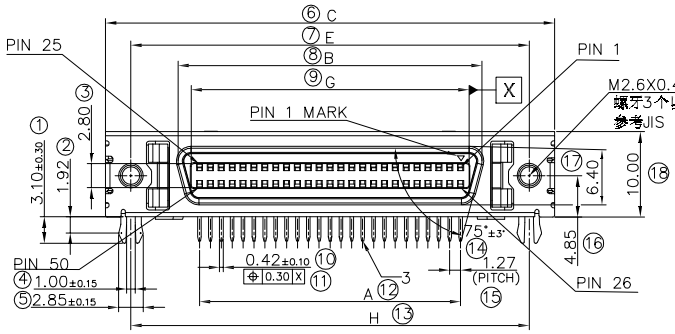
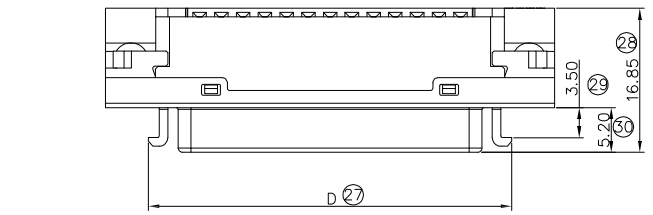

50	WLDBM9-5011A0171	30.48	35.48	52.40	42.40	46.50	30.48	32.5	46.50	
26	WLDBM9-2611A0171	15.24	20.24	37.16	27.16	31.26	15.24	17.2	31.26	
PIN NO.(N)	PART NO.	A	B	C	D	E	F	G	H	
5	HOOK	STEEL,SPCC,T=1.00							2	
4	SHELL	STEEL,SPCC,T=0.40							1	
3	TERMINAL	C5210,T=0.30							N	
2	GUIDE PLATE	LCP,UL94V-0, BLACK(Contain 25% regrind material)							1	
1	HOUSING	LCP,UL94V-0, BLACK(Contain 25% regrind material)							1	
ITEM	DESCRIPTION	REMARK							Q'TY	

REV.	REVISION RECORD	DATE		GENERAL TOLERANCES		SCALE: 1:1	NAME	DATE	PART.NO:	DWG.NO:		
AO	NEW RELEASE	22.05.09		LINEAR	ANGLES							APPROVED
			UNIT:mm	0.00±0.25	X'±3°	DESIGNER	Han_Gao	22.05.09	TITLE:		REV: A0	SHEET: 1/1
			SIZE: A4	0.000±0.10	X'X' ±2°	DRAWN	LanXuan_Hou	22.05.09	CONN, 1.27 PITCH RECEPTACLE WITH CLAMP			