

The product using material and processing must conform to the "WI-PZ-001" HSF technical standard control requirements

RoHS

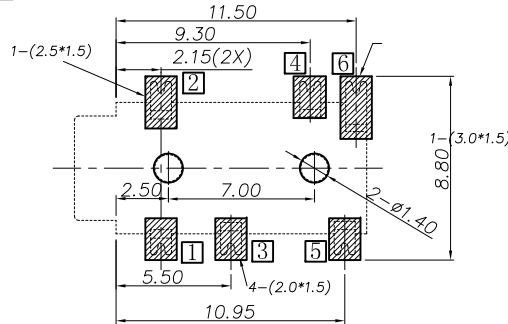

RECOMMENDED P. C. B. LAYOUT  
UNSPECIFIED TOLERANCE: ±0.05  
(TOP VIEW)

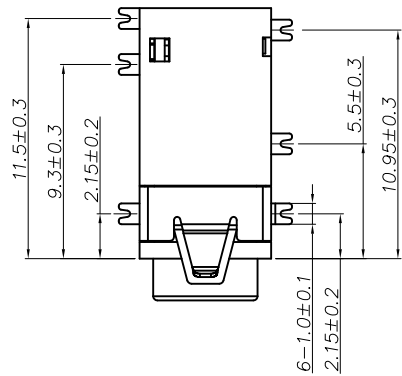
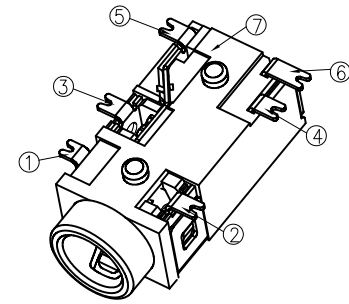
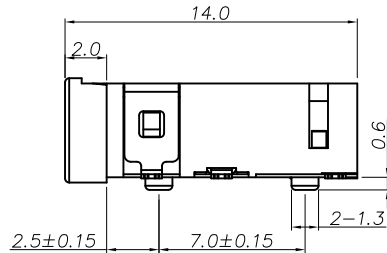
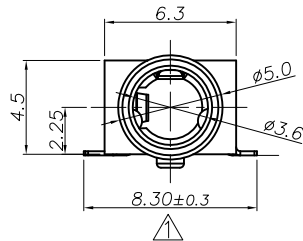

- Specification:
- Rating : DC 30V 0.5A.
  - Contact resistance: ≤50mΩ.  
After test: ≤100mΩ.
  - Insulation resistance: ≥100MΩ (500VDC).  
After test: ≥50MΩ.
  - Withstanding voltage: 500VAC.
  - Insertion and extraction force: 3N~30N.
  - life test: 5000cycles min.
  - Operation temperature range: -20°C ~ 70°C.
  - Preservative temperature range: -40°C ~ 85°C.

P/N:  
WLPJF9-062 X X X 071

PLATED: 1-AU, 8-AG

SCHEMATIC OPTION  
COLOUR: A-BLACK

Matching Plug

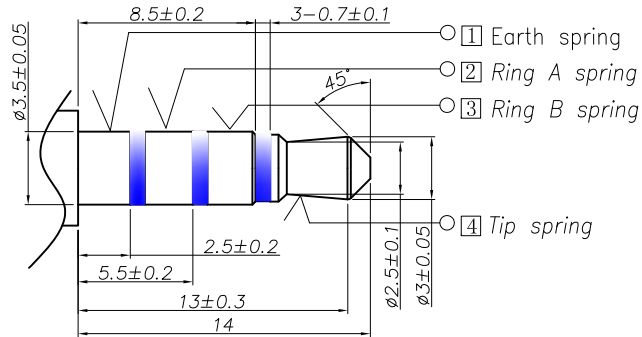

SCHEMATIC OPTION

Model No.	0	1	2
Schematic code			

⑦	Housing	1	PA10T UL94 V-0	BLACK
⑥	Shunt terminal ⑥	1	Phosphor Bronze T=0.2	Au
⑤	Shunt terminal ⑤	1	Phosphor Bronze T=0.2	Au
④	Tip spring ④	1	Phosphor Bronze T=0.2	Au
③	Ring B spring ③	1	Phosphor Bronze T=0.2	Au
②	Ring A spring ②	1	Phosphor Bronze T=0.2	Au
①	Earth spring ①	1	Phosphor Bronze T=0.2	Au

REV.	REVISION RECORD	DATE	GENERAL TOLERANCES	SCALE: 1:1	NAME	DATE	PART.NO:	DWG.NO:
A0	NEW RELEASE	21.01.13	LINEAR	APPROVED	Wang_jr	23.06.21	WLPJF9-0621A0071	ENDE05
A1	ADD Optimization	23.06.21	0.00±0.25	DESIGNER	Ou_jian	23.06.21	TITLE: DC PHONE JACK ∅3.5mm R/A SMT	
			0.000±0.10	DRAWN	Hou-lanxuan	23.06.21		



REV: A1 SHEET: 1/1