

RoHS Compliant

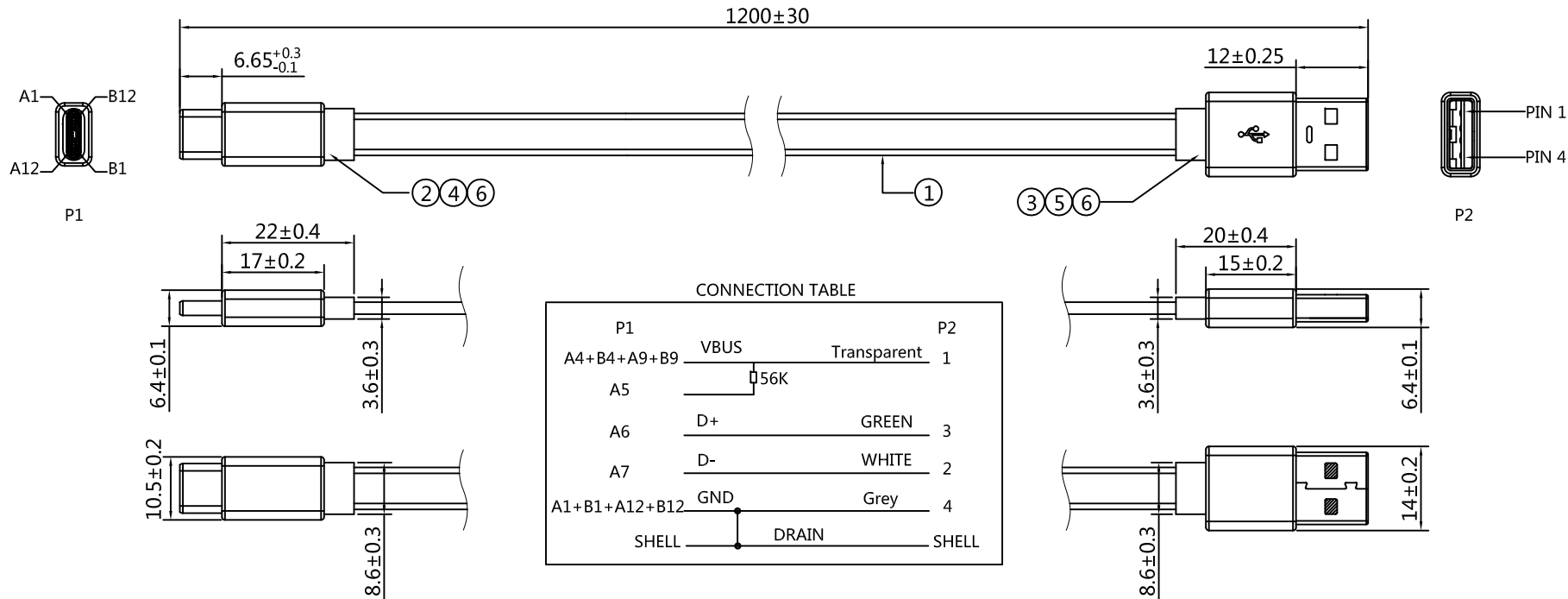

ELECTRICAL TEST:

1. OPEN/SHORT/INTERMITTENCE:100%
2. HI-POT:300V DC/SEC
3. INSULATION RESISTANCE:10MΩ Min, DC 300V/0.01S
4. CURRENT: 2A Max.
5. CONDUCTION TEST: 1Ω MAX.

⑥	OUTER MOLDING	TPE WHITE	8G
⑤	ABS SHELL	USB A/M ABS SHELL	1PCS
④	ABS SHELL	Type C ABS SHELL	1PCS
③	USB AM	USB A TYPE PLASTIC WHITE, CONTACT PLATED G/F, SHELL PLATED NICKEL	1PCS
②	TYPE-C PLUG	TYPE C 2.0 PLASTIC WHITE ,UL 94V-0 CONTACT PLATED G/F, WITH PCBA Rp 56KΩ , SHELL PLATED NICKEL	1PCS
①	RAW CABLE	NO-UL(30AWG*2C+D+A)*1P+23AWG*2C OD:7*2±0.2mm TPE JACKET WHITE	1.2M
NO.	NAME	SPECIFICATION STANDARD	QT'Y

MARK	REV.	DATE	DESCRIPTION	CHK.	APPD.	UNIT	UNIT	TH	DR.	CHK.	CHK.	APPD.	TITLE	PART NO.	NUMBER	SCALE	SHEET	REV.
△ X	X0	20.06.20	NEW EDITION	wyj	Joshua	mm	mm	mm	wyj	wyj	Joshua	Joshua	USB2.0 AM to Type C L=1200mm	JCT098-F001	ENDCA08	1:1	1/1	X0

JCTC® Shenglan Technology Co LTD
TERMINAL & CONNECTORS

RoHS Compliant

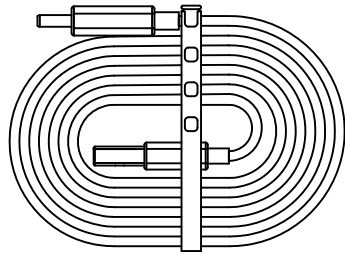

1. Tie the wire with silica gel;

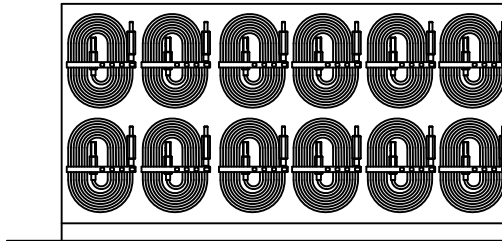

2. Each bag is packed with 28PCS, and the bag mouth is sealed with transparent glue, PE bag length 415mm * width 230mm;

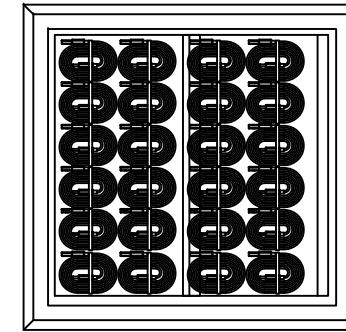

3. bags per layer 4* 28 =112PCS / layer It should be neatly arranged without messy extrusion;

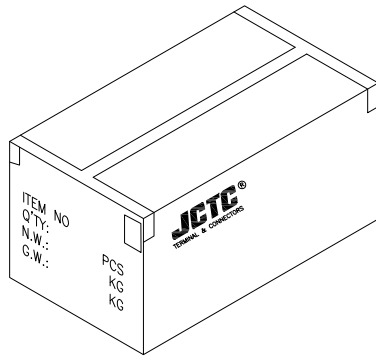

5. Put 2 packs of desiccant in each box, seal the box with transparent tape, seal the box with yellow tape, and fill with foam and other fillers;
6. In-factory labels need to be attached to the sides of the carton;

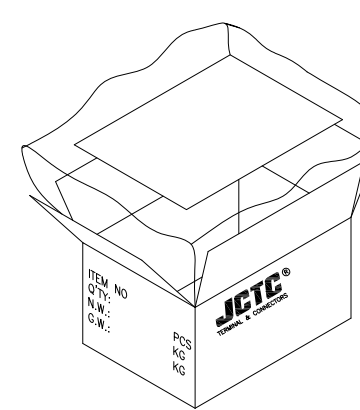

4. As shown in the figure, place the waterproof bag in the outer box and put 1PCS separator on each layer, and 5 boxes in a box * 112PCS = 560PCS / box (RER); Carton specifications: 380mm (L) * 320mm (W) * 280mm (H) Material K = K

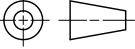
						一般公差 GENERAL TOLERANCE		绘图 DR.	wyj	 Shenglan Technology Co LTD TERMINAL & CONNECTORS			料号 PART NO.		
						X.X ±0.5	X' ±10'	校对 CHK.	wyj				JCT098-F001		
						X.XX ±0.3	X.X' ±5'	审核 APPD.	Josha	文件编号 NUMBER					
						X.XXX ±0.2	▲ MAJOR DIM.	核准 APPD.	Josha	ENDCA08					
△ X	X0	20.06.24	NEW EDITION	wyj	Josha	单位 UNIT		品名 TITLE			比例 SCALE	SHEET	版次 REV.		
MARK	REV.	DATE	DESCRIPTION	CHK.	APPD.	mm		USB2.0 AM to Type C L=1200mm			1:1	1/1	X0		
A		B		C		D		E		F					