

The product using material and processing must conform to the "WL-PZ-001"HSF technical standard control requirements

RoHS

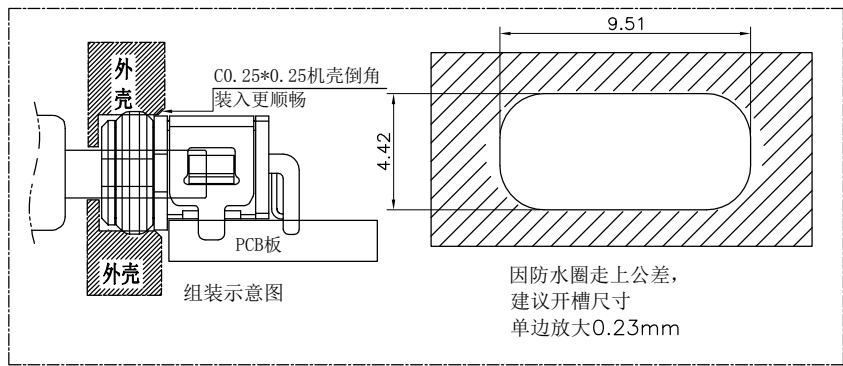

NOTE:  
 1.MATERIAL SPECIFICATION:  
 1-1.HOUSING:PA10T&LCP(G.F30%)  
 1-2.CONTACT:PHOSPHAR BRONZE C5191R-EH T=0.20mm  
 1-3.SHELL 1:SUS301 T=0.25mm  
 1-4.SHELL 2:SUS301 T=0.20mm  
 2.PLATING SPECIFICATION:  
 2-1.CONTACT:AU/NI PLATING ON CONTACT AREA.  
 2-2.SHELL:NI PLATING ON CONTACT AREA.  
 3.MECHANICAL PERFORMANCE:  
 3-1.INSERTION FORCE:3.5Kgf MIN  
 3-2.EXTRACTION FORCE:0.8Kgf MIN  
 3-3.DURABILITY: 10000 CYCLES.  
 4.ELECTRICAL PERFORMANCE:  
 4-1.RATED CURRENT:3A(PIN1&5),0.5A(PIN2&3&4)  
 4-2.VOLTAGE RATING:5V MAX  
 4-3.CONTACT RESISTANCE: 30mΩ MAX  
 4-4.INSULATION RESISTANCE: 100MΩ MIN  
 4-5.WITHSTANDING VOLTAGE: 500V AC  
 5.OPERATION TEMPERATURE RANGE:-40°C~85°C  
 6.WATER PROOFNESS:THIS PRODUCT IS BASED ON IPX8  
 7.PLUG INTERFACE DIMENSIONS COMFORM TO USB2.0 SPEC.  
 8.PACKAGE SPEC REEL  
 9.P/N:

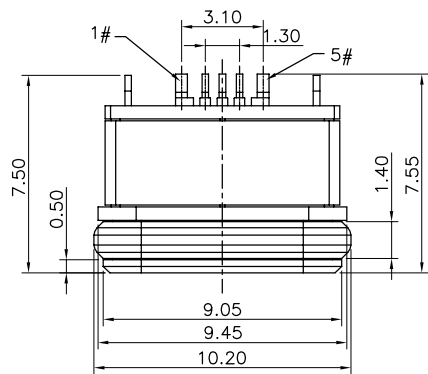
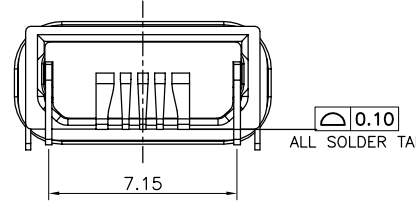
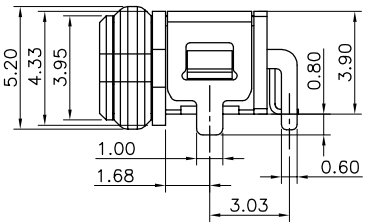
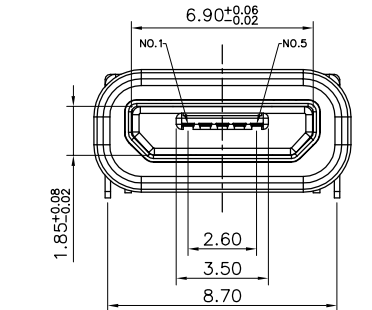

WLM2F9-05 2 X X X 062  
 PLATED: 1-G/F, 2-Au 3u", 5-Au 15u", 6-Au 30u"  
 HOUSING: 1-PA10T, 2-LCP  
 COLOUR: A-BLACK

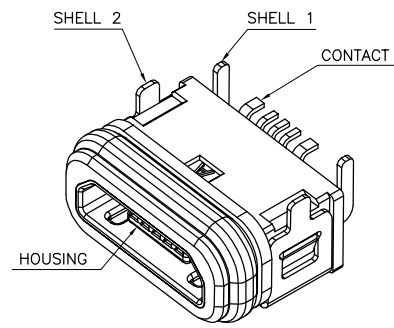
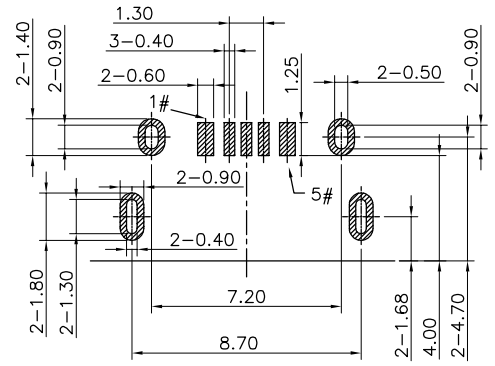
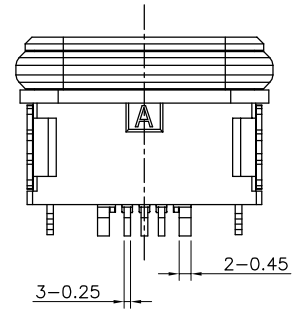

RECOMMENDED P.C.B. LAYOUT (TOP VIEW)  
 GENERAL TOLERANCE: ±0.05

Contact Number	Signal Name	Remarks
1#	VBUS	Power
2#	D-	Date-
3#	D+	Date+
4#	ID	Reserve or Gound
5#	GND	Gound

REV.	REVISION RECORD	DATE	GENERAL TOLERANCES		SCALE:	NAME	DATE	PART.NO:	DWG.NO:	 WanLian Teconology Co., Ltd
A0	NEW RELEASE	21.01.13	LINEAR	ANGLES	1:1	Wang_jr	21.01.13	WLM2F9-052XXX062	ENDE05	
			0.0±0.35	X°REF±6°	APPROVED	Han_Gao	21.01.13	TITLE: Micro USB 5P/F B Type SMT IPX8		REV: A0 SHEET: 1/1
			0.00±0.25	X°±3°	DESIGNER	Zijun_Huang	21.01.13			
			UNIT:mm	0.00±0.10	X°X'±2°	DRAWN				