

The product using material and processing must conform to the "WL-PZ-001"HSF technical standard control requirements

RoHS

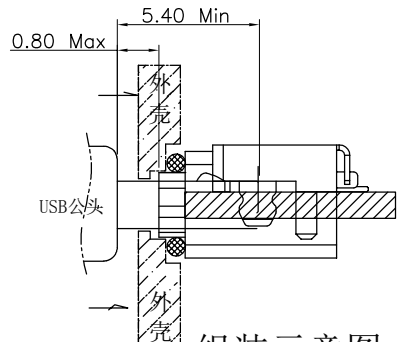

组装示意图

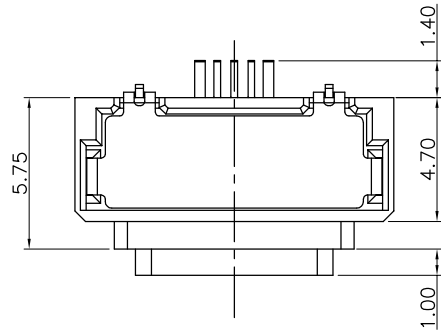
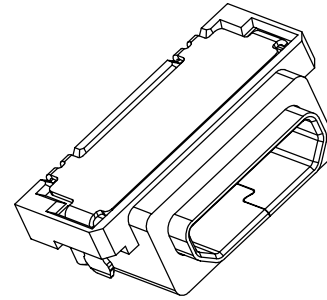

- NOTE:
- MATERIAL SPECIFICATION:
 - HOUSING:PA10T&LCP(G.F30%)
 - CONTACT:PHOSPHAR BRONZE C5191R-EH T=0.20
 - SHELL:SUS301 T=0.30
 - PLATING SPECIFICATION:
 - CONTACT:AU/NI PLATING ON CONTACT AREA.
 - SHELL:NI PLATING ON CONTACT AREA.
 - MECHANICAL PERFORMANCE:
 - INSERTION FORCE:3.5Kgf MIN
 - EXTRACTION FORCE:0.8Kgf MIN
 - DURABILITY: 10000 CYCLES.
 - ELECTRICAL PERFORMANCE:
 - RATED CURRENT:3A(PIN1&5),0.5A(PIN2&3&4)
 - VOLTAGE RATING:5V MAX
 - CONTACT RESISTANCE: 30mΩ MAX
 - INSULATION RESISTANCE: 100MΩ MIN
 - WITHSTANDING VOLTAGE: 500V AC
 - OPERATION TEMPERATURE RANGE:-40°C~85°C
 - WATER PROOFNESS:THIS PRODUCT IS BASED ON IPX8
 - PLUG INTERFACE DIMENSIONS COMFORM TO USB2.0 SPEC.
 - PACKAGE SPEC-REEL
 - P/N: WLM2F9-05 8 X X X 060

- PLATED:
- 1-G/F
 - 2-Au 3u"
 - 5-Au 15u"
 - 6-Au 30u"
- HOUSING:
- 1-PA10T
 - 2-LCP
- COLOUR:
- A-BLACK

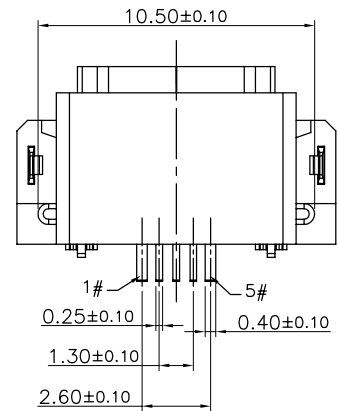
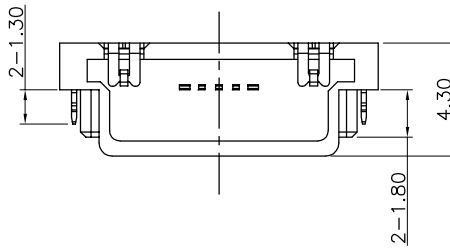
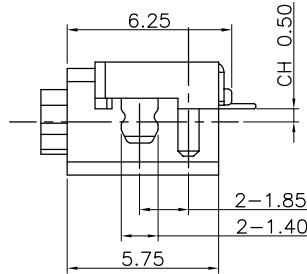
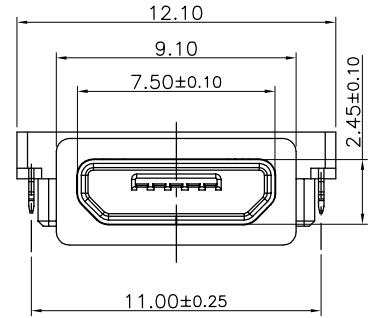

产品尾部点胶水, PCB尾部请预留足够间隙.

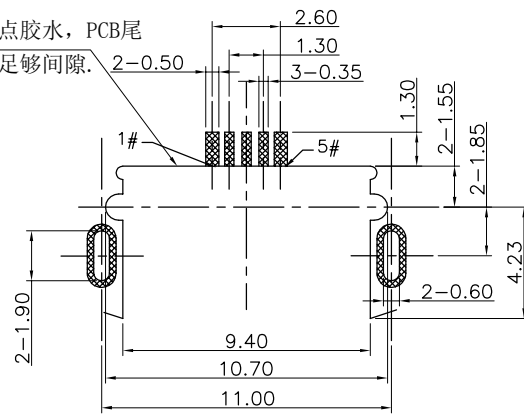

Recommended P.C.B. Layout
Unspecified tolerance:±0.05
(Top view)

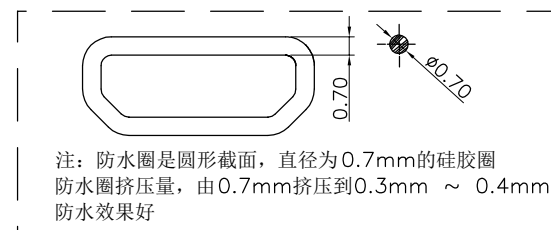

Contact Number	Signal Name	Remarks
1#	VBUS	Power
2#	D-	Date-
3#	D+	Date+
4#	ID	Reserve or Gound
5#	GND	Gound

REV.	REVISION RECORD	DATE	GENERAL TOLERANCES		SCALE:	NAME	DATE	PART.NO:	DWG.NO:
A0	NEW RELEASE	21.01.13	LINEAR	ANGLES	1:1	Wang_jr	21.01.13	WLM2F9-058XXX060	ENDE05
			0.0±0.35	X°REF±6°	APPROVED	Han_Gao	21.01.13	TITLE: Micro USB 5P/F SMT B Type IPX8	REV: A0
			0.00±0.25	X°±3°	DESIGNER	Zijun_Huang	21.01.13		
			UNIT:mm	0.00±0.10	X°X' ±2°	DRAWN			



WanLian Teconology Co., Ltd