

The product using material and processing must conform to the "WL-PZ-001" HSF technical standard control requirements

RoHS

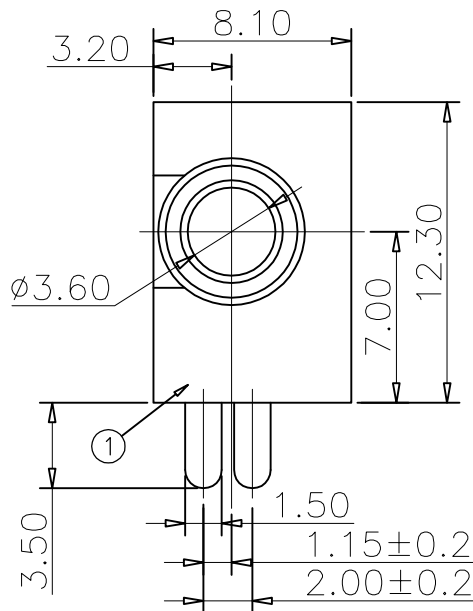
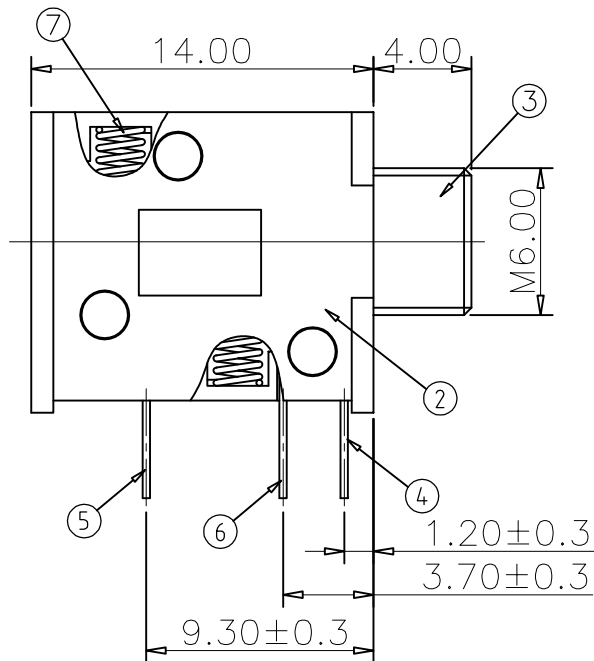

- NOTE:
- MATERIAL SPECIFICATION:
 - 1-1.HOUSING:PBT COLOUR:BLACK
 - 1-2.COVER:PBT COLOUR:BLACK
 - 1-3.CAP:BRASS
 - 1-4.TERMINAL 1:BRASS T=0.30mm
 - 1-5.TERMINAL 2:PHOSPHOR BRONZE T=0.30mm
 - 1-6.TERMINAL 3:PHOSPHOR BRONZE T=0.30mm
 - 1-7.SPRING:STAINLESS STEEL BLACK OXIDE FINISH.
 - PLATING SPECIFICATION:
 - 2-1.CAP:NI PLATING
 - 2-2.TERMINAL 1/2/3:AG PLATING ON CONTACT AREA.
 - MECHANICAL PERFORMANCE:
 - 3-1.INSERTION AND EXTRACTION FORCE:3N~30N
 - 3-2.DURABILITY: 5000 CYCLES MIN.
 - ELECTRICAL PERFORMANCE:
 - 4-1.RATED CURRENT:0.5A
 - 4-2.NOMINAL VOLTAGE:30V
 - 4-3.CONTACT RESISTANCE: 50mΩ MAX, AFTER TEST:100mΩ MAX
 - 4-4.INSULATION RESISTANCE:100MΩ MIN AFTER TEST:50MΩ MIN
 - 4-5.WITHSTANDING VOLTAGE: 500V AC
 - 5.OPERATION TEMPERATURE RANGE:-20°C~+70°C
 - P/N: WLPJF9-03 X 1 1 0 062

PLATED: 1.G/F
7.SN
8.AG

HOUSING: 1.PBT BLACK

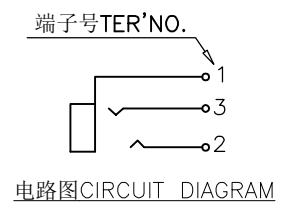
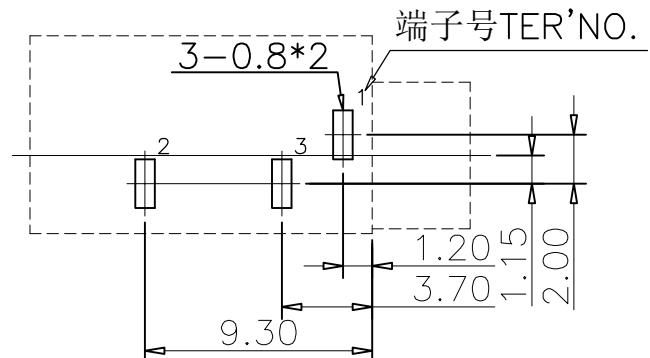

PCB孔尺寸PCB HOLES (顶视图TOP VIEW) t=1.6mm
注NOTE:未注公差GENERAL TOLERANCE ±0.1mm

REV.	REVISION RECORD	DATE		GENERAL TOLERANCES		SCALE: 1:1	NAME	DATE	PART.NO: WLPJF9-03X110062	DWG.NO: ENDE05	
A0	NEW RELEASE	21.01.13		LINEAR	ANGLES	APPROVED	Wang_jr	21.01.13			
			UNIT:mm	0.00±0.25	X'±3'	DESIGNER	Han_Gao	21.01.13	TITLE: PHONE JACK		
			SIZE: A4	0.000±0.10	X'X' ±2'	DRAWN	Zijun_Huang	21.01.13			