

The product using material and processing must conform to the "WI-PZ-001" HSF technical standard control requirements

RoHS

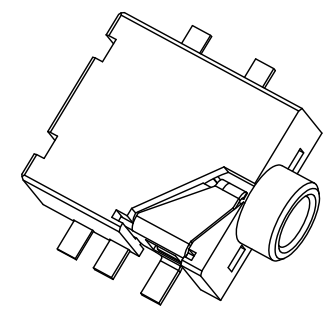

- NOTE:
- MATERIAL SPECIFICATION:
 - HOUSING: PA9T UL V-0
 - COVER: PA9T UL94 V-0
 - EARTH SPRING: PHOSPHOR BRONZE T=0.3mm
 - TIP SPRING: STAINLESS STEEL T=0.2mm
 - RING SPRING: STAINLESS STEEL T=0.2mm
 - SHUNT TERMINAL: PHOSPHOR BRONZE T=0.2mm.
 - PLATING SPECIFICATION:
 - BUSHING: NI PLATING.
 - EARTH TERMINAL:
 - GOLD/SILVER PLATING ON CONTACT AREA.
 - TIP SPRING: GOLD/SILVER PLATING
 - RING SPRING: GOLD/SILVER PLATING
 - SHUNT TERMINAL: GOLD/SILVER PLATING
 - MECHANICAL PERFORMANCE:
 - INSERTION AND EXTRACTION FORCE: 3N~30N
 - DURABILITY: 5000 CYCLES.
 - ELECTRICAL PERFORMANCE:
 - RATED CURRENT: 0.5A
 - NOMINAL VOLTAGE: 30V
 - CONTACT RESISTANCE: 30mΩ MAX
AFTER TEST: 50mΩ MAX
 - INSULATION RESISTANCE: 100MΩ MIN
AFTER TEST: 50MΩ MIN
 - WITHSTANDING VOLTAGE: 500V AC
 - OPERATION TEMPERATURE RANGE: -20°C~+70°C
PRESERVATIVE TEMPERATURE RANGE: -40°C~85°C
 - P/N: WLPJF9-05 X 1 1 X 051

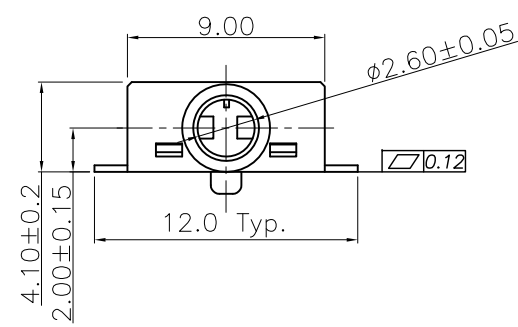
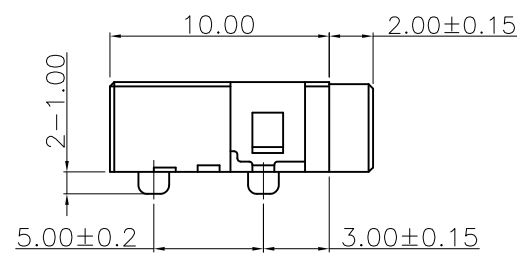
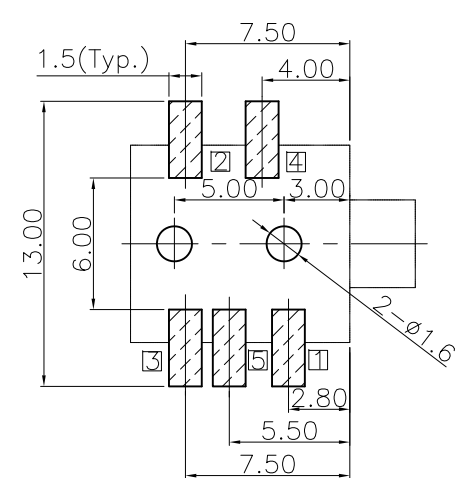
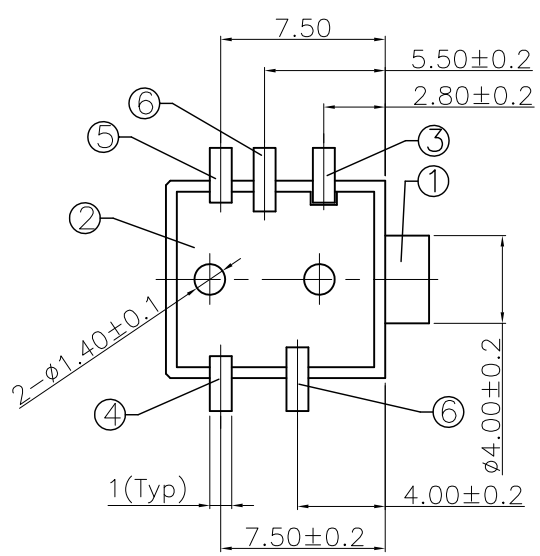
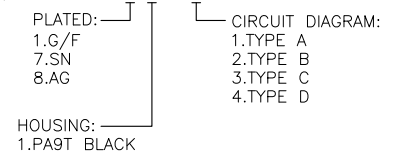

RECOMMENDED P.C.B. LAYOUT
UNSPECIFIED TOLERANCE: ±0.05
(COPPER-SIDED VIEW)

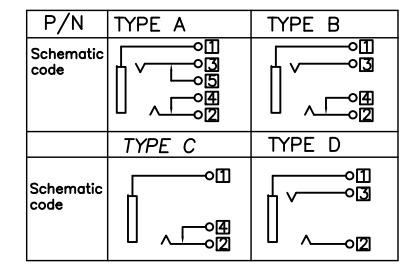
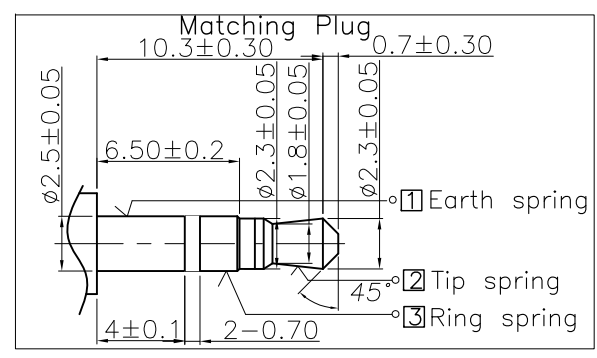

Circuit Diagram □: Terminal NO.

REV.	REVISION RECORD	DATE	GENERAL TOLERANCES		SCALE:	NAME	DATE	PART NO:	DWG NO:	 WanLian Teconology Co., Ltd
A0	NEW RELEASE	21.01.13	LINEAR	ANGLES	1:1	Wang_jr	21.01.13	WLPJF9-05X11X051	ENDE05	
			0.0±0.35	X'REF±6°	APPROVED	Han_Gao	21.01.13	TITLE:	REV: A0	
			0.00±0.25	X'±3°	DESIGNER	Zijun_Huang	21.01.13	φ2.5 PHONE JACK	SHEET: 1/1	
			UNIT:mm	0.00±0.10	X'X'±2°	DRAWN				