

The product using material and processing must conform to the "WI-PZ-001" HSF technical standard control requirements

RoHS

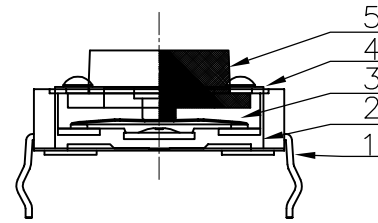
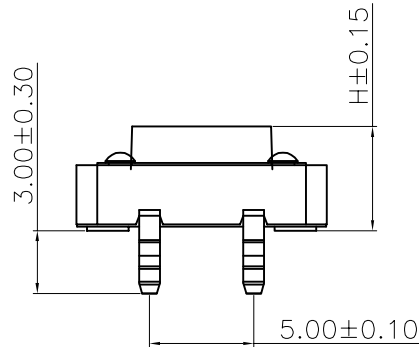
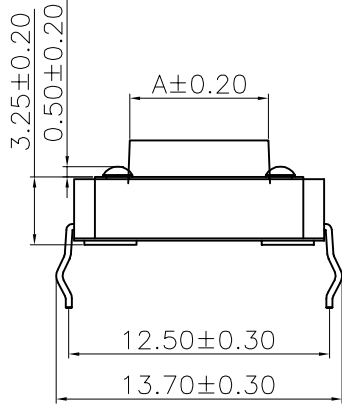

NOTE:  
 1.MATERIAL SPECIFICATION:  
 1-1.CONTACTS:BRASS T=0.3mm  
 1-2.HOUSING:PPA COLOUR:BLACK  
 1-3.SHRAPNEL:φ8.5 STAINLESS STEEL  
 1-4.COVER: BRASS  
 1-5.BUTTON: PPA COLOUR:BLACK  
 2.PLATING SPECIFICATION:  
 2-1.CONTACT:AG PLATED ON CONTACT AREA  
 2-2.SHRAPNEL:AG PLATED.  
 2-3.COVER:SN PLATED  
 3.ELECTRICAL PERFORMANCE:  
 3-1.RATING CURRENT:50mA DC  
 3-2.RATING VOLTAGE:12V DC  
 3-3.CONTACT RESISTANCE: 100mΩ MAX;  
 3-4.INSULATION RESISTANCE:100MΩ MIN  
 3-5.WITHSTANDING VOLTAGE: AC 250V/50HZ,1MIN  
 4.MECHANICAL PERFORMANCE:  
 4-1.DURABILITY: 100000 CYCLES.  
 5.OPERATION TEMPERATURE RANGE:-20°C~+85°C  
 6.P/N: WLSW10-04 1 8 A X 062

PLATED: 8.AG  
 COLOUR: A.BLACK  
 A.H=4.30mm  
 B.H=4.50mm  
 C.H=5.00mm  
 D.H=5.50mm  
 E.H=6.00mm  
 F.H=6.50mm  
 G.H=7.00mm  
 H.H=7.50mm  
 I.H=8.00mm  
 .....

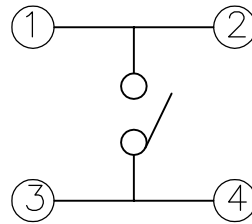
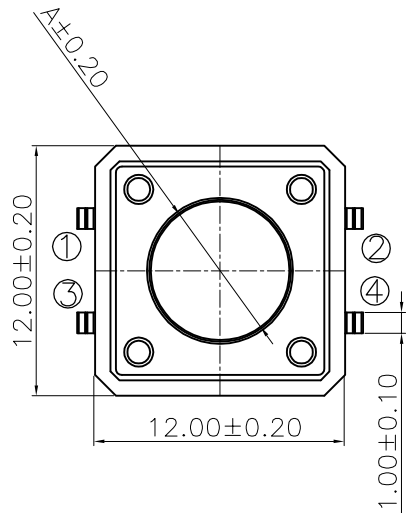

原理图

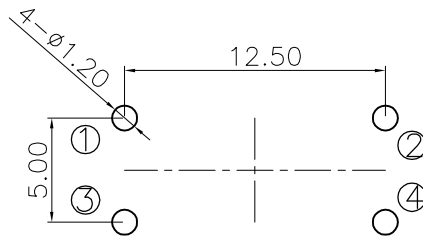

印刷线路板开孔

| H/mm | A/mm |
|------|------|
| 4.3  | 6.8  |
| 4.5  | 6.8  |
| 5.0  | 6.65 |
| 5.5  | 6.6  |
| 6.0  | 6.6  |
| 6.5  | 6.6  |
| 7.0  | 6.55 |
| 7.5  | 6.5  |
| 8.0  | 6.5  |

| N (按力值gf) |     |     |     |       |
|-----------|-----|-----|-----|-------|
| 100       | 160 | 250 | 350 | ..... |

| REV. | REVISION RECORD | DATE     | GENERAL TOLERANCES |          | SCALE: 1:1 | NAME        | DATE     | PART.NO:         | DWG.NO:    |
|------|-----------------|----------|--------------------|----------|------------|-------------|----------|------------------|------------|
| A0   | NEW RELEASE     | 21.01.13 | LINEAR             | ANGLES   | APPROVED   | Wang_jr     | 21.01.13 | WLSW10-0418AX062 | ENDE05     |
|      |                 |          | 0.0±0.35           | X*REF±6° | DESIGNER   | Han_Gao     | 21.01.13 | TITLE:           |            |
|      |                 |          | 0.00±0.25          | X'±3°    | DRAWN      | Zijun_Huang | 21.01.13 | TACT SWITCH      |            |
|      |                 |          | UNIT:mm            | X*X'±2°  |            |             |          |                  | REV: A0    |
|      |                 |          | SIZE: A4           |          |            |             |          |                  | SHEET: 1/1 |

WanLian Teconology Co., Ltd