

The product using material and processing must conform to the "WI-PZ-001" HSF technical standard control requirements

RoHS

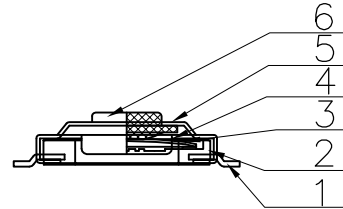
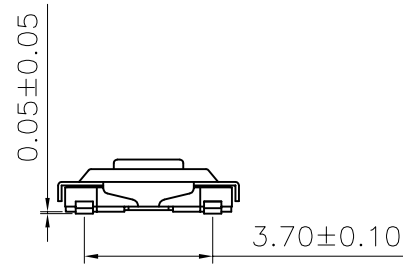
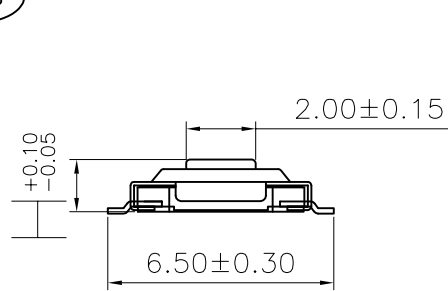

NOTE:

- 1.MATERIAL SPECIFICATION:
  - 1-1.CONTACTS:PHOSPHOR COPPER T=0.15mm
  - 1-2.HOUSING:PPA COLOUR:BLACK
  - 1-3.SHRAPNEL:STAINLESS STEEL
  - 1-4.DUST-PROOF MEMBRANE:POLYIMIDE COLOUR:YELLOW
  - 1-5.COVER: SPCC ACID PICKLING
  - 1-6.BUTTON: BRASS ACID PICKLING
- 2.PLATING SPECIFICATION:
  - 2-1.CONTACT:AG PLATING ON CONTACT AREA
  - 2-2.SHRAPNEL:AG PLATING.
- 3.ELECTRICAL PERFORMANCE:
  - 3-1.RATING CURRENT:50mA DC
  - 3-2.RATING VOLTAGE:12V DC
  - 3-3.CONTACT RESISTANCE: 100mΩ MAX;
  - 3-4.INSULATION RESISTANCE:100MΩ MIN
  - 3-5.WITHSTANDING VOLTAGE: AC 250V/50HZ,1MIN
- 4.MECHANICAL PERFORMANCE:
  - 4-1.DURABILITY: 100000 CYCLES.
- 5.OPERATION TEMPERATURE RANGE:-20°C~+85°C
- 6.PACKAGE SPEC: REEL
- 7.P/N:

WLSW10-04 2 8 A X 046

PLATED:  
8.AG  
COLOUR:  
A.BLACK

A.H=1.50mm  
B.H=2.00mm  
C.H=2.50mm  
D.H=3.10mm  
E.H=4.00mm  
F.H=4.30mm  
G.H=5.00mm  
H.H=6.00mm  
I.H=7.00mm  
.....

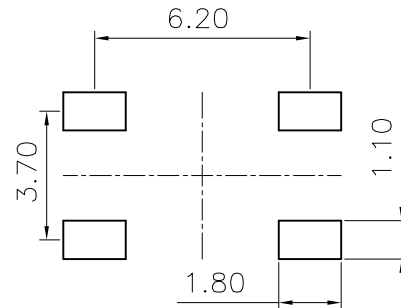
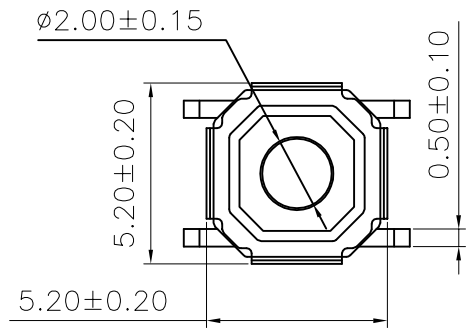

PCB印刷板 单位: mm

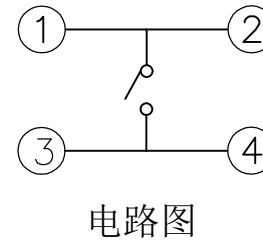

电路图

N (按力值gf)				
100	160	250	350	.....

REV.	REVISION RECORD	DATE	UNIT:mm	GENERAL TOLERANCES		SCALE: 1:1	NAME	DATE	PART.NO:	DWG.NO:	 WanLian Teconology Co., Ltd
A0	NEW RELEASE	21.01.13		LINEAR	ANGLES	APPROVED	Wang_jr	21.01.13	WLSW10-0428AX046	ENDE05	
			0.00±0.25	X°±3'	DESIGNER	Han_Gao	21.01.13	TITLE: TACT SWITCH		REV: A0	SHEET: 1/2
			SIZE: A4	0.000±0.10	X°X' ±2'	DRAWN	Zijun_Huang	21.01.13			

The product using material and processing must conform to the "WI-PZ-001" HSF technical standard control requirements

PULL OUT DIRCTION  
出料方向

RoHS

φ330

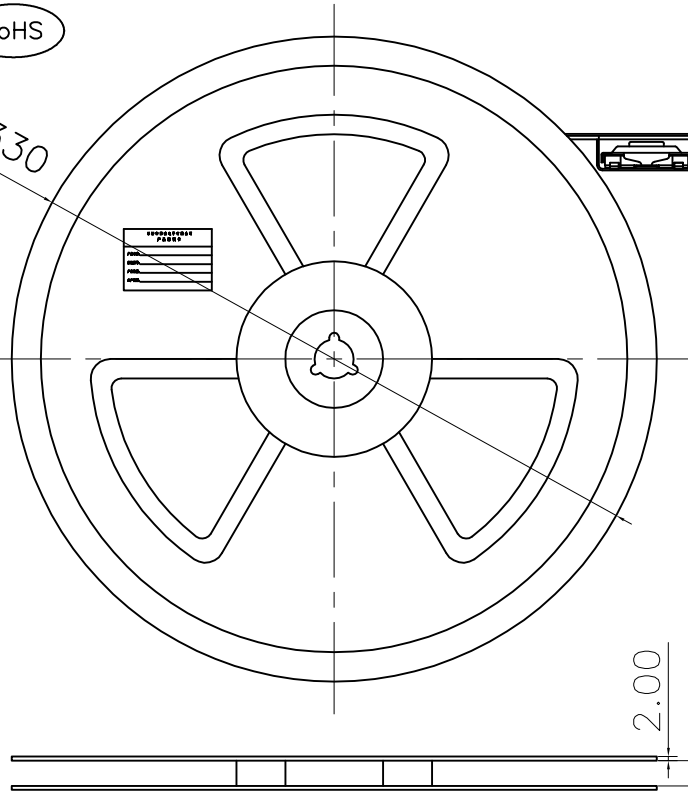

12.50  
2.00

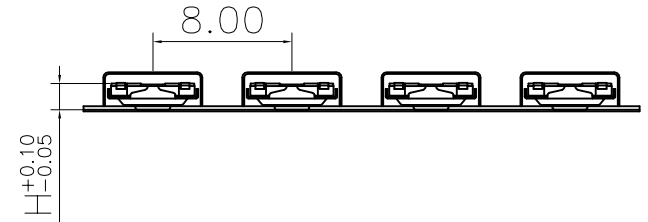
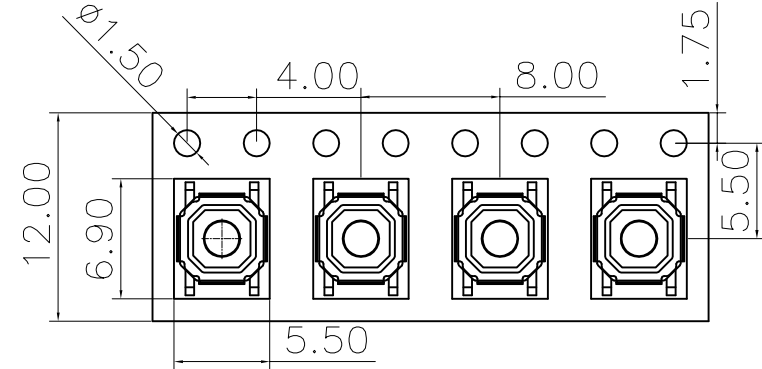
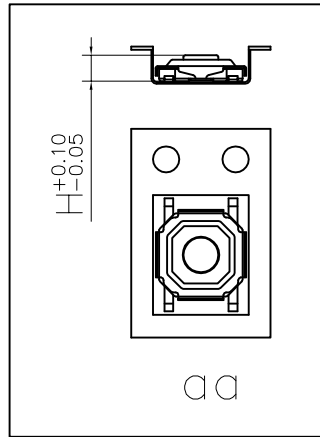

技术要求:

1. 本产品不含环境危险物质，适用于RoHS指令2011/65/EU要求。
2. 吸塑盒：用长6.9mm，宽5.5mm，编带定位孔间距为4±0.05mm。
3. 编带封塑时，一定要注意其封塑牢固度，无因封带开裂而导致产品脱落等不良现象。
4. 卷盘起始段要预留5到10PCS以上的空槽位置，防止卷盘内圆卷圈过小导致产品焊脚损坏；卷盘末端预留一外圈的空槽，防止卷盘碰撞对产品的损失；一卷盘按产品高度规格对应的要求数量进行编带。

部件规格表

H (产品总高/mm)	B (料带筒深mm)	序号	部件名称	部件材料	部件用量	其它
1.5	1.9	1	卡件	0.15磷铜	1PCS	镀银白色
1.6	1.9	2	基座	PPA	1PCS	黑色
1.7	1.9	3	弹片	不锈钢	1PCS	镀银白色
1.8	2.2	4	防尘膜	聚酰亚胺(杜邦)	1PCS	黄色
2.0	2.2	5	盖板	SPCC	1PCS	酸洗
2.2	2.6	6	按钮	黄铜	1PCS	酸洗
2.5	2.6					
.....	.....					
N (按力值gf)						
100	160	250	350	.....		

REV.	REVISION RECORD	DATE	GENERAL TOLERANCES	SCALE:	NAME	DATE	PART.NO:	DWG.NO:	 WanLian Teconology Co., Ltd
A0	NEW RELEASE	21.01.13	LINEAR	1:1	Wang_jr	21.01.13	WSLW10-0428AX046	ENDE05	
			0.0±0.35	APPROVED	Han_Gao	21.01.13	TITLE:	REV: A0	
			0.00±0.25	DESIGNER	Zijun_Huang	21.01.13	TACT SWITCH PACKAGE DRAWING	SHEET: 2/2	
			UNIT:mm						
			SIZE: A4						
			0.000±0.10	DRAWN					