

The product using material and processing must conform to the "WI-PZ-001" HSF technical standard control requirements

RoHS

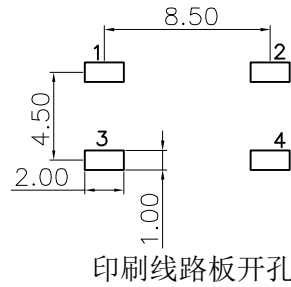

产品零部件剖析图

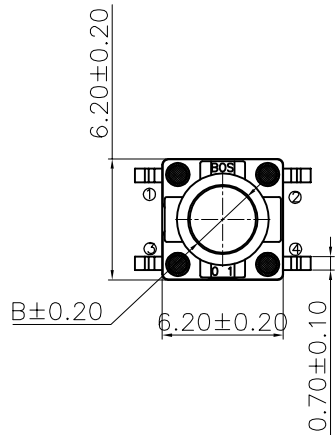
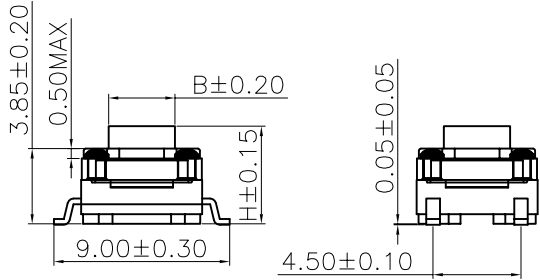
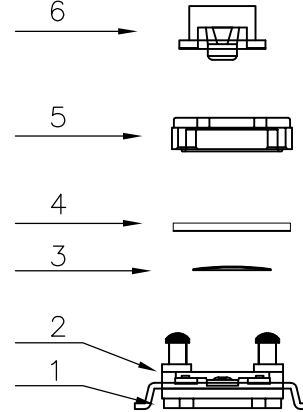

NOTE:

- MATERIAL SPECIFICATION:
 - 1-1.CONTACTS:BRASS T=0.3mm
 - 1-2.HOUSING:PPA COLOUR:BLACK
 - 1-3.SHRAPNEL:φ4 STAINLESS STEEL 210GF
 - 1-4.WATERPROOF COMPOSITE VINYL: POLYIMIDE COLOUR:YELLOW AND BLACK
 - 1-5.COVER: PPA COLOUR:BLACK
 - 1-6.BUTTON: PPA COLOUR:BLACK
- PLATING SPECIFICATION:
 - 2-1.CONTACT:AG PLATED ON CONTACT AREA
 - 2-2.SHRAPNEL:AG PLATED.
- ELECTRICAL PERFORMANCE:
 - 3-1.RATING CURRENT:50mA DC
 - 3-2.RATING VOLTAGE:12V DC
 - 3-3.CONTACT RESISTANCE: 100mΩ MAX;
 - 3-4.INSULATION RESISTANCE:100MΩ MIN
 - 3-5.WITHSTANDING VOLTAGE: AC 250V/50HZ,1MIN
- MECHANICAL PERFORMANCE:
 - 4-1.DURABILITY: 100000 CYCLES.
 - 4-2.WATERPROOF:IP67
- OPERATION TEMPERATURE RANGE:-20°C~+85°C
- PACKAGE SPEC: REEL
- P/N:

WLSW10-04 2 8 A X 055

PLATED: 8.AG
COLOUR: A.BLACK
A.H=4.30mm
B.H=4.50mm
C.H=5.00mm
D.H=5.50mm
E.H=6.00mm
F.H=6.50mm
G.H=7.00mm
H.H=7.50mm
I.H=8.00mm
.....

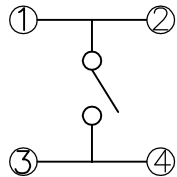

原理图

H	A
总高/mm	按钮顶部尺寸/mm
4.3	3.4
4.5	3.4
5.0	3.4
5.5	3.25
6.0	3.3
6.5	3.15
7.0	3.1
7.5	3.1
8.0	3.15

N (按力值gf)				
130	180	250	350

REV.	REVISION RECORD	DATE	GENERAL TOLERANCES		SCALE:	NAME	DATE	PART.NO:	DWG.NO:
A0	NEW RELEASE	21.01.13	LINEAR	ANGLES	1:1	Wang_jr	21.01.13	WLSW10-0428AX055	ENDE05
			0.0±0.35	X*REF±6°	APPROVED	Han_Gao	21.01.13	TITLE:	 WanLian Teconology Co., Ltd
			0.00±0.25	X*±3°	DESIGNER	Zijun_Huang	21.01.13	TACT SWITCH	
			0.000±0.10	X*X'±2°	DRAWN				

REV: A0 SHEET: 1/2

The product using material and processing must conform to the "WI-PZ-001" HSF technical standard control requirements

PULL OUT DIRCTION

出料方向

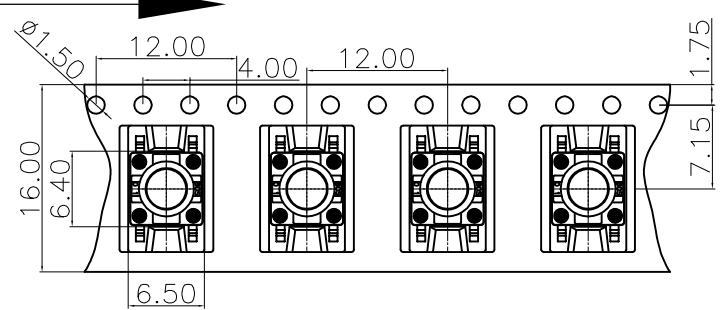
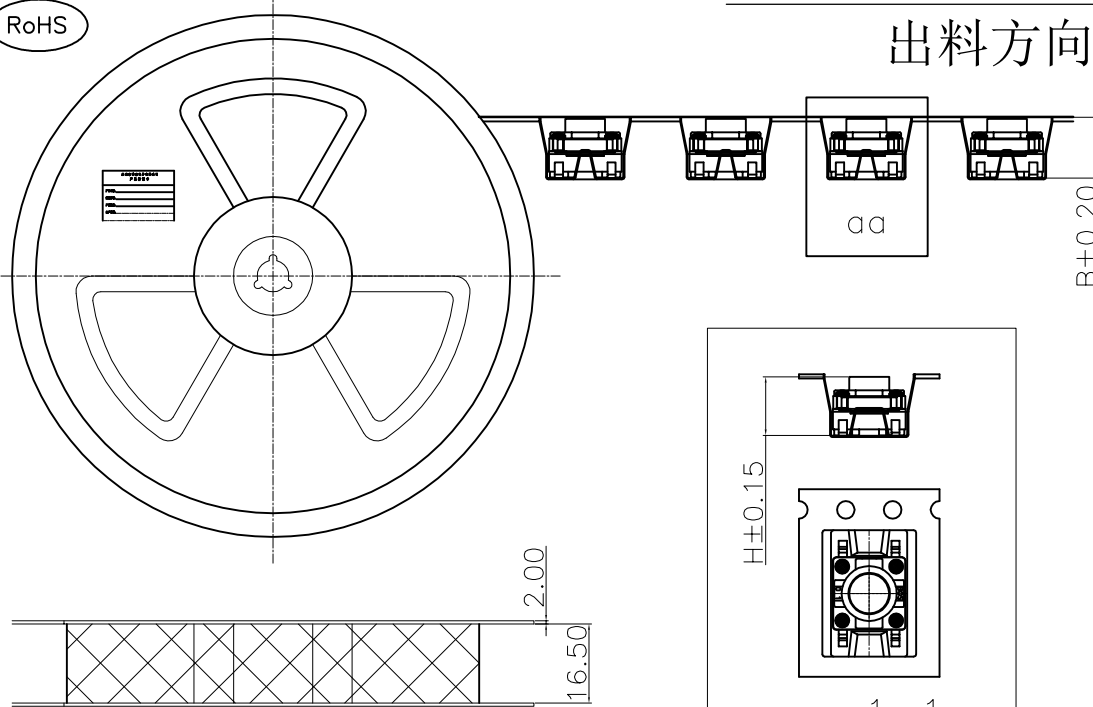

H (总高mm)	B (料带筒深mm)
4.3	5.2
4.5	5.2
5.0	5.2
5.5	5.7
6.0	6.2
6.5	6.7
7.0	7.2
7.5	7.7
8.0	8.2
8.5	8.7
9.0	9.2
9.5	9.7
.....

N (按力值gf)				
130	180	250	350

卷盘

技术要求

1. 本产品不含环境危险物质，适用于RoHS指令2011/65/EU要求。
2. 吸塑盒：用长6.4mm，宽6.5mm，编带定位孔间距为 4 ± 0.05 mm。
3. 编带封塑时，一定要注意其封塑牢固度，无因封带开裂而导致产品脱落等不良现象。
4. 卷盘起始段要预留5到10PCS的空槽，防止卷盘内圆卷圈过小导致产品焊脚损坏；卷盘末端预留一外圈的空槽或加一圈保护带，防止卷盘碰撞对产品的损失；一卷盘按1000PCS的数量进行编带。

部件规格表

序号	部件名称	部件材料	部件用量	其它
1	卡件	0.3黄铜	1PCS	镀银白色
2	基座	PPA	1PCS	黑色
3	弹片	Φ4进口不锈钢覆银	1PCS	210gf
4	防水复合黑胶	聚酰亚胺(防水黑胶+防水膜)	1PCS	黄色+黑色
5	盖板	PPA	1PCS	黑色
6	按钮	PPA	1PCS	黑色
7				
8				

REV.	REVISION RECORD	DATE	GENERAL TOLERANCES	SCALE: 1:1	NAME	DATE	PART.NO:	DWG.NO:
A0	NEW RELEASE	21.01.13	LINEAR 0.0±0.35	APPROVED	Wang_jr	21.01.13	WLSW10-0428AX055	ENDE05
			ANGLES 0.0±0.25	DESIGNER	Han_Gao	21.01.13	TITLE: TACT SWITCH PACKAGE DRAWING	
			UNIT:mm SIZE: A4	DRAWN	Zijun_Huang	21.01.13		
			0.00±0.10					



REV: A0 SHEET: 2/2