

The product using material and processing must conform to the "WI-PZ-001"HSF technical standard control requirements

RoHS

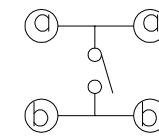

SCHEMATIC

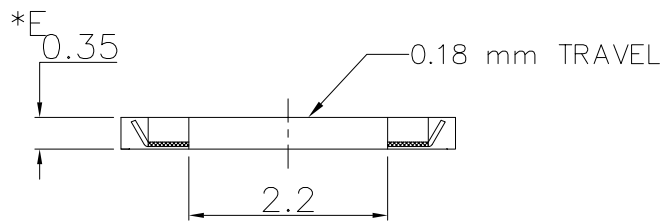
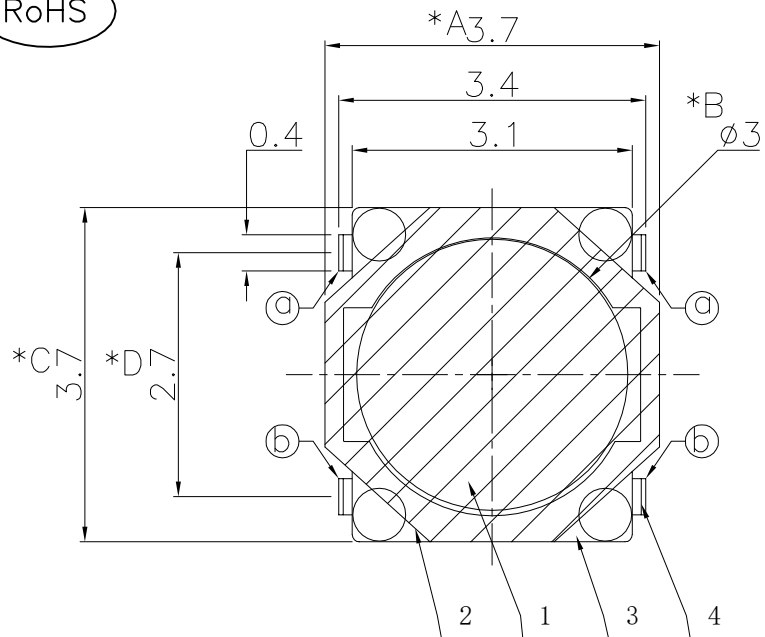
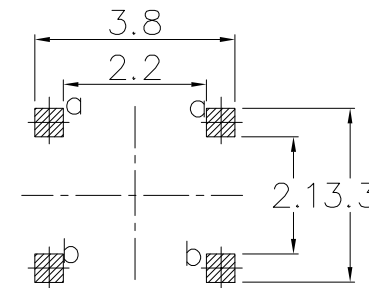

P.C.B.LAYOUT

(force) F=	2	160gf/180gf
	3	250 gf

PART ORDER:
WLSW10-04 2 X X 0 022

PLATING: 8-Ag COLOUR:
A:Black
K:White

* CRITICAL DIMENSION

4	SCREEN	PET	1	YELLOW
3	CONTACT	SUS	1	Ag CLAD
2	CASE	LCP	1	BLACK
1	TERMINAL	PBS STRIP	4	Ag COATING
NO.	PART NAME	MATERIAL	QTY	FINISHING

REV.	REVISION RECORD	DATE		GENERAL TOLERANCES		SCALE:	NAME	DATE	PART.NO:	DWG.NO:			
A0	NEW RELEASE	21.01.13		LINEAR	ANGLES	1:1						APPROVED	Wang_jr
			UNIT:mm	0.00±0.25	X'±3'	DESIGNER	Ding_bo	21.01.13	TITLE: TACT SWITCH			REV: A0	SHEET: 1/1
			SIZE: A4	0.000±0.10	X'X' ±2'	DRAWN	Ou_jian	21.01.13					