

The product using material and processing must conform to the "WI-PZ-001"HSF technical standard control requirements

RoHS

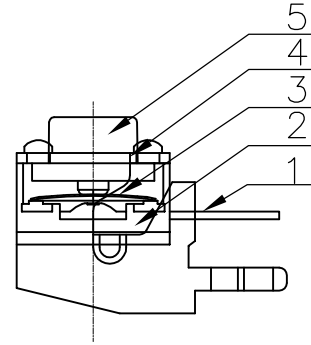
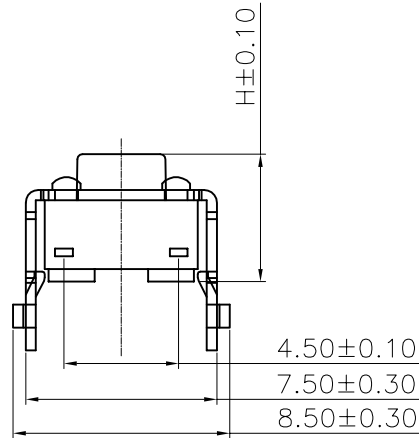
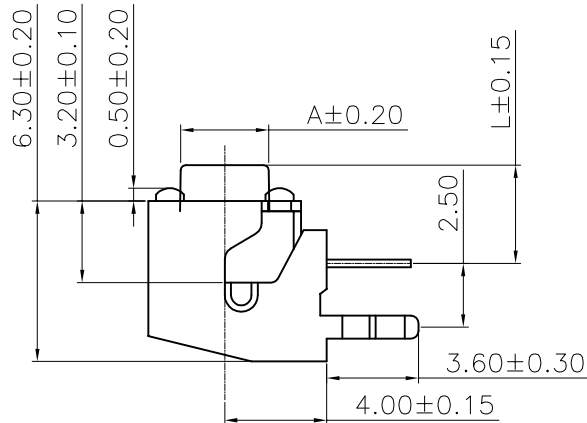

NOTE:
 1.MATERIAL SPECIFICATION:
 1-1.CONTACTS:BRASS T=0.3mm
 1-2.HOUSING:PPA(HTN52G40BL) COLOUR:BLACK
 1-3.SHRAPNEL:φ5 STAINLESS STEEL 250GF
 1-4.COVER: SPCC
 1-5.BUTTON: PPA COLOUR:BLACK
 2.PLATING SPECIFICATION:
 2-1.CONTACT:AG PLATED ON CONTACT AREA
 2-2.SHRAPNEL:AG PLATED.
 2-3.COVER:COPPER TIN ALLOY PLANTED.
 3.ELECTRICAL PERFORMANCE:
 3-1.RATING CURRENT:50mA DC
 3-2.RATING VOLTAGE:12V DC
 3-3.CONTACT RESISTANCE: 100mΩ MAX;
 3-4.INSULATION RESISTANCE:100MΩ MIN
 3-5.WITHSTANDING VOLTAGE: AC 250V/50HZ,1MIN
 4.MECHANICAL PERFORMANCE:
 4-1.DURABILITY: 100000 CYCLES.
 5.OPERATION TEMPERATURE RANGE:-20°C~+85°C
 6.P/N: WLSW19-02 1 8 A X 053

PLATED: 8.AG
 COLOUR: A.BLACK
 A.H=4.30mm
 B.H=4.50mm
 C.H=5.00mm
 D.H=5.50mm
 E.H=6.00mm
 F.H=6.50mm
 G.H=7.00mm
 H.H=7.50mm
 I.H=8.00mm

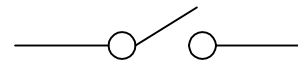
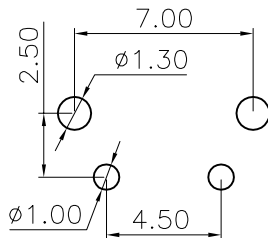
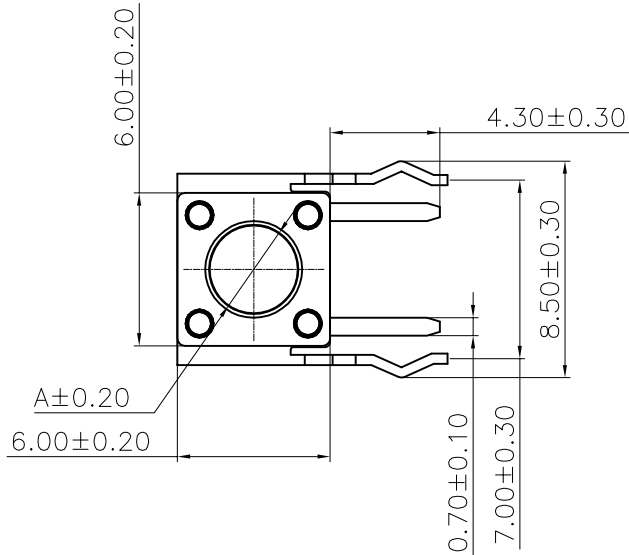

原理图

印刷电路板开孔

H(产品总高/mm)	A(按钮高度尺寸/mm)	L(按钮底座长度尺寸/mm)
4.3	3.5	3.15
4.5	3.5	3.35
5.0	3.45	3.85
5.5	3.35	4.35
6.0	3.2	4.85
6.5	3.15	5.35
7.0	3.3	5.85
7.5	3.1	6.35
8.0	3.1	6.85

N (按力值gf)				
100	160	250	350
7.5	3.1	6.35		
8.0	3.1	6.85		

REV.	REVISION RECORD	DATE	UNIT:mm	GENERAL TOLERANCES		SCALE: 1:1	NAME	DATE	PART.NO: WLSW19-0218AX053	DWG.NO: ENDE05	 WanLian Teconology Co., Ltd
A0	NEW RELEASE	21.01.13		SIZE: A4	LINEAR	ANGLES	APPROVED	Wang_jr			
				0.0±0.35	X°REF±6°	DESIGNER	Han_Gao	21.01.13			
				0.00±0.25	X'±3°	DRAWN	Zijun_Huang	21.01.13			
				0.00±0.10	X''±2°						