

The product using material and processing must conform to the "WI-PZ-001"HSF technical standard control requirements

RoHS

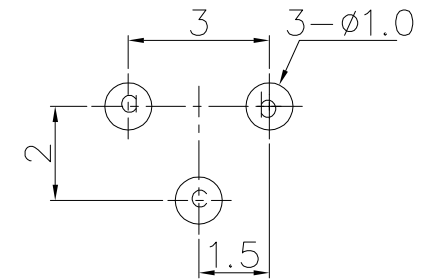

(height) L=	□ A	3.8mm
	□ 4.3	4.3mm
	□ 4.5	4.5mm
	■ B	5.0mm
	□ C	7.0mm
	□ 1.0	10.0mm
(force) F=	□ L	停用130gf
	□ S	160/180gf
	■ H	250gf

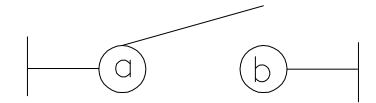
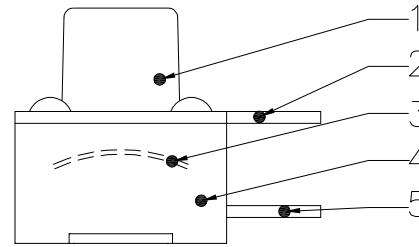
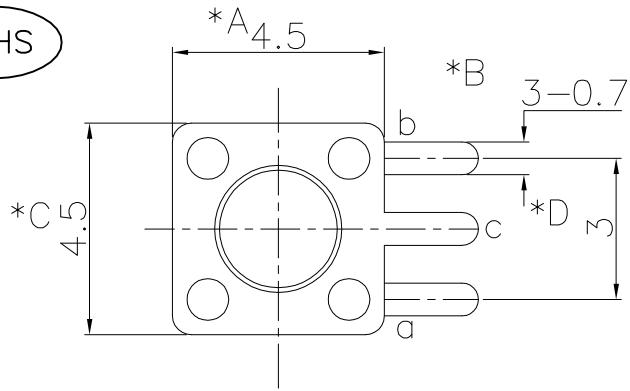
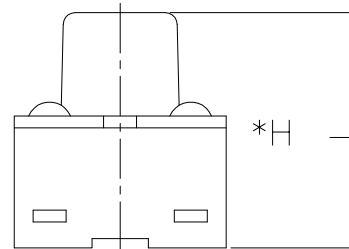
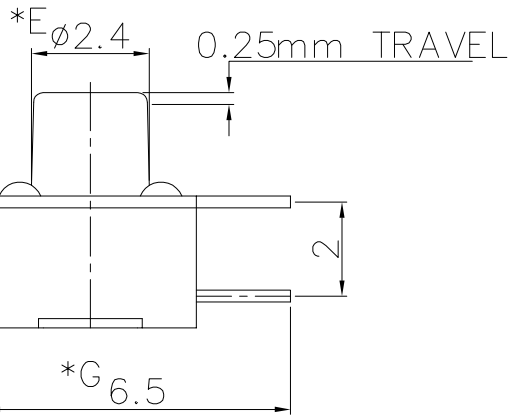

PART ORDER:

WLSW19-02 1 X X 0 014

PLATING: 8-Ag COLOUR: A:Black  
K:White

\* CRITICAL DIMENSION

5	TERMINAL	BRASS	2	Ag COATING
4	CASE	PA	1	BLACK
3	CONTACT	SUS	1	Ag CLAD
2	COVER	SPN STRIP	1	Ni COATING
1	STEM	PA	1	BLACK
NO.	PART NAME	MATERIAL	QTY	FINISHING

REV.	REVISION RECORD	DATE	☉	GENERAL TOLERANCES		SCALE:	NAME	DATE	PART.NO:	DWG.NO:
A0	NEW RELEASE	21.01.13		LINEAR	ANGLES	1:1				
				0.0±0.35	X'REF±6°	APPROVED	Wang_jr	21.01.13	WLSW19-021XX0014	ENDE05
				0.00±0.25	X'±3'	DESIGNER	Ding_bo	21.01.13	TITLE:	
				0.000±0.10	X'X' ±2'	DRAWN	Ou_jian	21.01.13	TACT SWITCH	



REV: A0 SHEET: 1/1