

The product using material and processing must conform to the "WI-PZ-001"HSF technical standard control requirements

RoHS

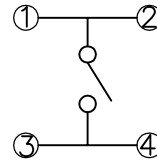

原理图

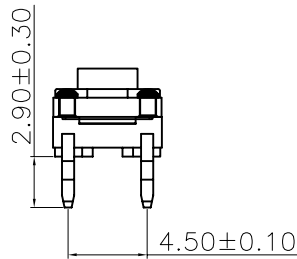
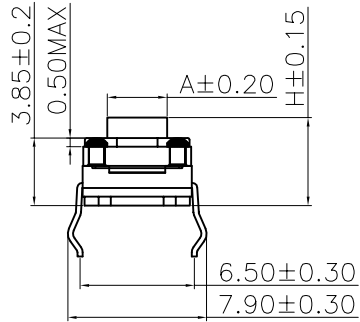
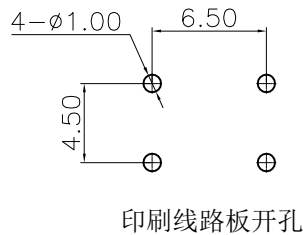
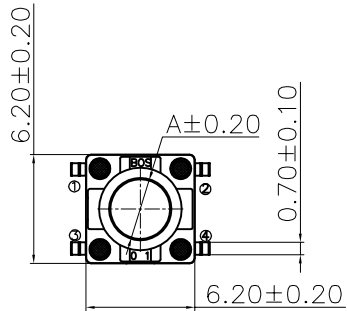

印刷线路板开孔

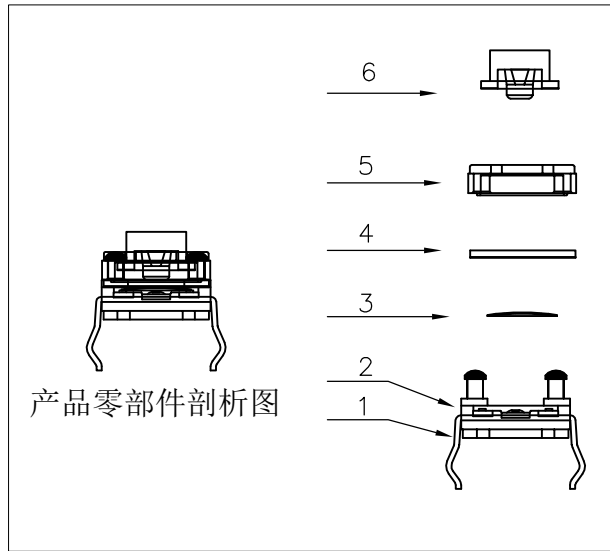

产品零部件剖析图

NOTE:

1.MATERIAL SPECIFICATION:

- 1-1.CONTACTS:BRASS T=0.3mm
- 1-2.HOUSING:PPA COLOUR:BLACK
- 1-3.SHRAPNEL:φ4 STAINLESS STEEL
- 1-4.WATERPROOF COMPOSITE VINYL: POLYIMIDE COLOUR:BLACK AND YELLOW
- 1-5.COVER: PPA COLOUR:BLACK
- 1-6.BUTTON: PPA COLOUR:BLACK

2.PLATING SPECIFICATION:

- 2-1.CONTACT:AG PLATING ON CONTACT AREA
- 2-2.SHRAPNEL:AG PLATING.

3.ELECTRICAL PERFORMANCE:

- 3-1.RATING CURRENT:50mA DC
- 3-2.RATING VOLTAGE:12V DC
- 3-3.CONTACT RESISTANCE: 100mΩ MAX;
- 3-4.INSULATION RESISTANCE:100MΩ MIN
- 3-5.WITHSTANDING VOLTAGE: AC 250V/50HZ,1MIN

4.MECHANICAL PERFORMANCE:

- 4-1.DURABILITY: 100000 CYCLES.
- 4-2.WATERPROOF:IP67

5.OPERATION TEMPERATURE RANGE:-20°C~+85°C

6.P/N: WLSW19-04 1 8 A X 052

PLATED:
8.AG
COLOUR:
A.BLACK

A.H=4.30mm
B.H=4.50mm
C.H=5.00mm
D.H=5.50mm
E.H=6.00mm
F.H=6.50mm
G.H=7.00mm
H.H=7.50mm
I.H=8.00mm
.....

| H 总高/mm | A 按钮顶部尺寸/mm |
|------------|----------------|
| 4.3 | 3.4 |
| 4.5 | 3.4 |
| 5.0 | 3.4 |
| 5.5 | 3.25 |
| 6.0 | 3.3 |
| 6.5 | 3.15 |
| 7.0 | 3.1 |
| 7.5 | 3.1 |
| 8.0 | 3.15 |

| N (按力值gf) | | | | |
|-----------|-----|-----|-----|-------|
| 130 | 180 | 250 | 350 | |
| | | | | 8.0 |
| | | | | 3.15 |

| REV. | REVISION RECORD | DATE | UNIT:mm | GENERAL TOLERANCES | | SCALE: 1:1 | NAME | DATE | PART.NO: | DWG.NO: | WanLian Teconology Co., Ltd |
|------|-----------------|----------|---------|--------------------|----------|---------------|-------------|----------|-------------|------------------|-----------------------------|
| A0 | NEW RELEASE | 21.01.13 | | SIZE: A4 | LINEAR | ANGLES | APPROVED | Wang_jr | 21.01.13 | WLSW19-0418AX052 | |
| | | | | 0.0±0.35 | X°REF±6° | DESIGNER | Han_Gao | 21.01.13 | TITLE: | | REV: A0 |
| | | | | 0.00±0.25 | X°±3° | DRAWN | Zijun_Huang | 21.01.13 | TACT SWITCH | | SHEET: 1/1 |
| | | | | 0.00±0.10 | X°X' ±2° | | | | | | |



REV: A0 SHEET: 1/1