

The product using material and processing must conform to the "WI-PZ-001"HSF technical standard control requirements

RoHS+HF

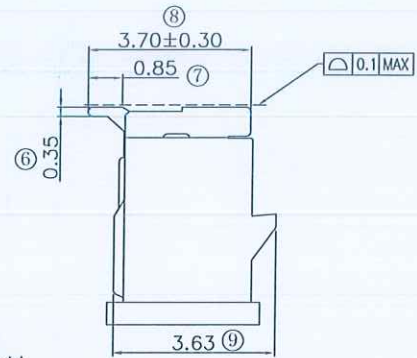

缺口为浇口工艺, 减少自动机加盖卡料, 缺口位置不固定, 也可在另一侧

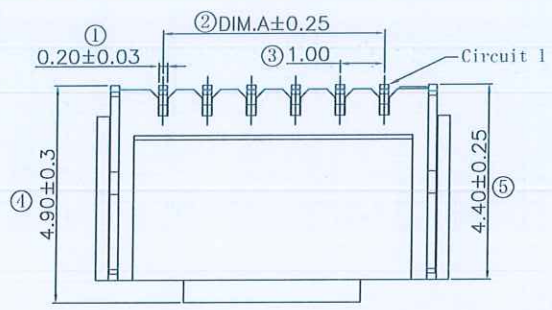
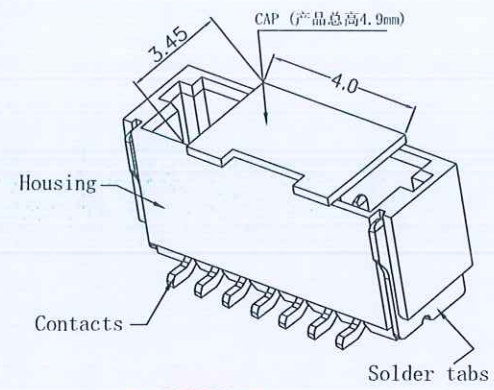
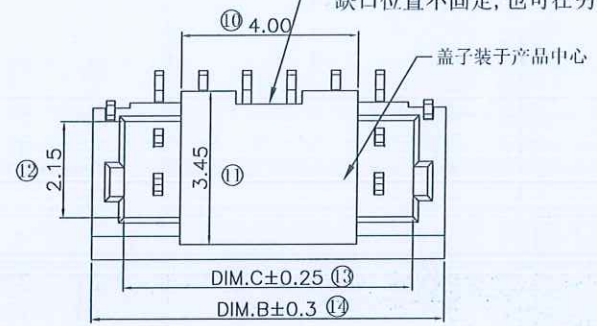

- NOTE:
- MATERIAL SPECIFICATION:
 - CONTACT: PHOSPHOR BRONZE
 - SOLDER TABS: PHOSPHOR BRONZE
 - HOUSING: LCP UL94V-0
 - CAP: LCP UL94V-0
 - PLATING SPECIFICATION:
 - CONTACTS: BRIGHT TIN PLATED OVER ALL.
 - SOLDER TABS: BRIGHT TIN PLATED OVER ALL.
 - ELECTRICAL PERFORMANCE:
 - CURRENT RATING: 1.0A
RATED VOLTAGE : 50V AC/DC
 - CONTACT RESISTANCE: 20 mΩ MAX
 - INSULATION RESISTANCE: 100MΩ Min
 - DIELECTRIC WITHSTANDING : 500V
 - ENVIRONMENTAL PERFORMANCE:
 - OPERATING TEMPERATURE: -25°C~+85°C.
 - PACKAGE SPEC: REEL/1500pcs
 - P/N:

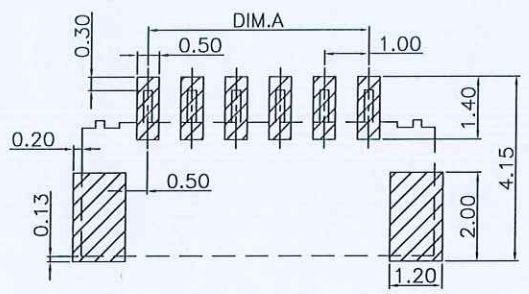
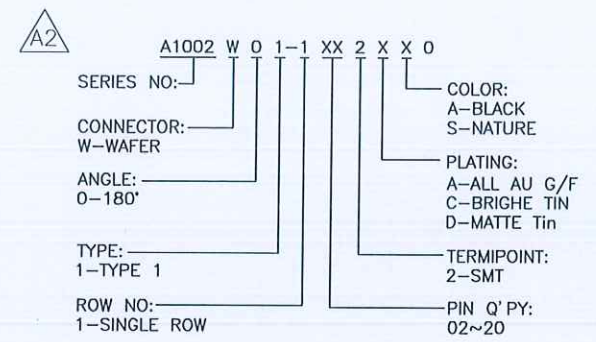

Recommend PCB Layout

Ordering Information & Dimensions

Circuit	Dimensions (mm)			Circuit	Dimensions (mm)		
	A	B	C		A	B	C
02	1.00	4.00	2.45	12	11.00	14.00	12.45
03	2.00	5.00	3.45	13	12.00	15.00	13.45
04	3.00	6.00	4.45	14	13.00	16.00	14.45
05	4.00	7.00	5.45	15	14.00	17.00	15.45
06	5.00	8.00	6.45	16	15.00	18.00	16.45
07	6.00	9.00	7.45	17	16.00	19.00	17.45
08	7.00	10.00	8.45	18	17.00	20.00	18.45
09	8.00	11.00	9.45	19	18.00	21.00	19.45
10	9.00	12.00	10.45	20	19.00	22.00	20.45
11	10.00	13.00	11.45				



REV.	REVISION RECORD	DATE	GENERAL TOLERANCES	SCALE: 1:1	NAME	DATE	PART.NO:	DWG.NO:
A0	NEW RELEASE	21.11.17	LINEAR	1:1			A1002W01-1XX2XX0	ENDE05
A1	盖子增加缺口	22.10.20	0.0±0.35	APPROVED	李华	26.1.27		
A2	PART NUMBER RENEWAL		0.00±0.25	DESIGNER	李华	26.01.27		
			0.000±0.10	DRAWN	黄宇	26.01.27	TITLE: Pitch 1.00mm 180°SH 单排立贴带锁扣 Wafer	

REV: A2 SHEET: 1/2

The product using material and processing must conform to the "WI-PZ-001" HSF technical standard control requirements

RoHS+HF

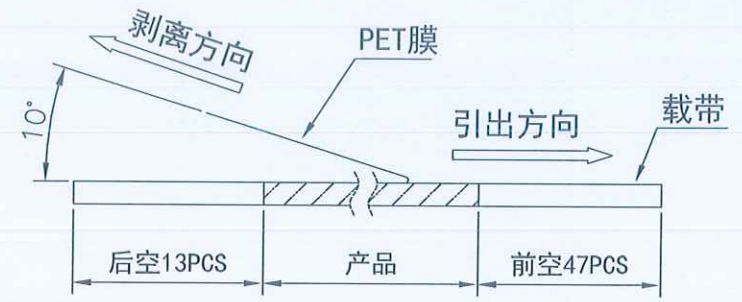
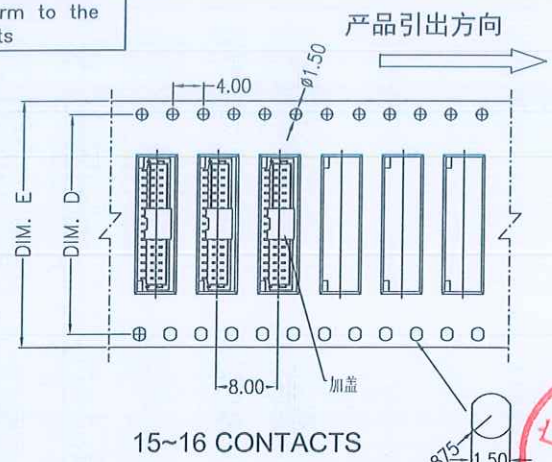
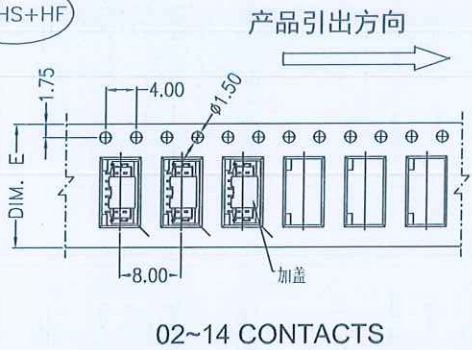

(PET膜剥离示意图)

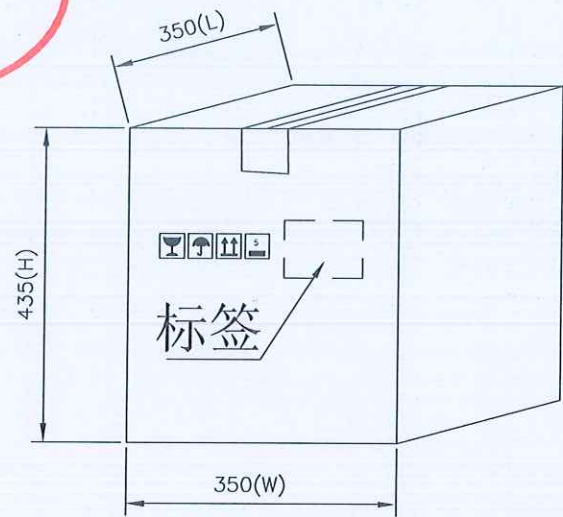
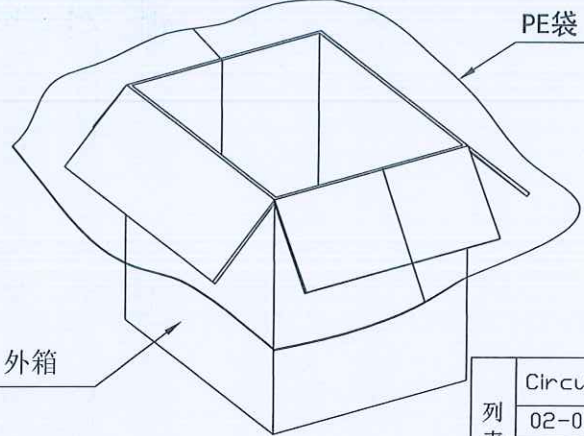
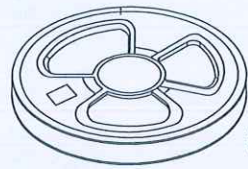
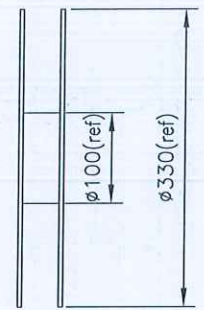
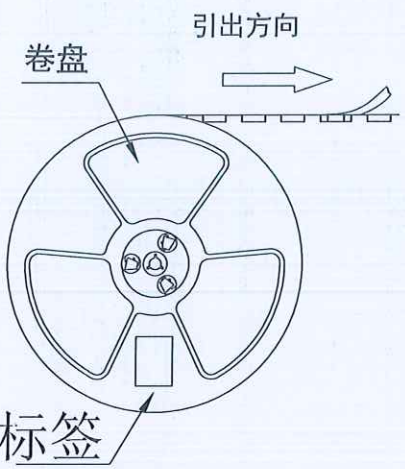

包装说明:

1. 把成品包入卷盘中, 每盘装1500PCS, 卷盘上贴上标签, 将装好产品的卷盘放进外箱中, 外箱内先套一个大PE袋, 外箱上贴贴上标签. 2. 所有材料有害物控制需符合ROHS标准.

列表一	Circuit	DIM.D	DIME	PETwidth	Q'ty/reel	Packing (Reel/Car ton)
	02-05	-	16	12.8	1500PCS	20/Reel
	06-14	-	24	20.7	1500PCS	15/Reel
	15-16	28.4	32	25.5	1500PCS	11/Reel

REV.	REVISION RECORD	DATE	GENERAL TOLERANCES	SCALE: 1:1	NAME	DATE	PART.NO:	DWG.NO:
A0	NEW RELEASE	21.11.17	LINEAR	APPROVED	张	26.1.21	A1002W01-1XX2XX0	ENDE05
A1	盖子增加缺口	22.10.20	0.0±0.35	DESIGNER	张	26.01.21	TITLE: Pitch 1.00mm 180° SH 单排立贴带锁扣 Wafer	REV: A2 SHEET: 2/2
A2	PART NUMBER RENEWAL	:	0.00±0.25	DRAWN	黄	26.01.21		
			0.000±0.10					

