



The product using material and processing must conform to the "WI-PZ-001"HSF technical standard control requirements

RoHS

NOTE:

- 1.MATERIAL SPECIFICATION:
  - 1-1.HOUSING:PA9T,UL94V-0 
  - 1-2.CAP:PA6T,UL94V-0
  - 1-2.CONTACTS:BRASS
- 2.PLATING SPECIFICATION:
  - 2-1.CONTACTS: GOLD-FLASH(15u") ON CONTACT AREA  
MATTE TIN PLATING ON SOLDER TAILS AREA.
- 4.ELECTRICAL PERFORMANCE:
  - 4-1. RATED CURRENT : 1A AC,DC  
RATED VOLTAGE : 150V AC/DC
  - 4-2.INSULATION RESISTANCE: 500MΩ MIN  
CONTACT RESISTANCE : 30mΩ(MAX.)
  - 4-3.WITHSTANDING VOLTAGE: 500V AC/minute
- 5.ENVIRONMENTAL PERFORMANCE:
  - OPERATING TEMPERATURE: -25°C~+85°C.
- 6.PACKAGE SPEC:REEL
- 7.P/N:

 A1252 W 0 1-2 XX 2 X X 0

SERIES NO: \_\_\_\_\_ COLOR: A-BLACK

CONNECTOR: \_\_\_\_\_ PLATING: A-ALL AU G/F  
W-WAFER C-BRIGHE TIN  
5-AU 15U"

ANGLE: \_\_\_\_\_ TERMIPOINT: 2-SMT  
0-180°

TYPE: \_\_\_\_\_ PIN Q'PY: 10~40  
1-TYPE 1

ROW NO: \_\_\_\_\_  
2-DOUBLE ROW

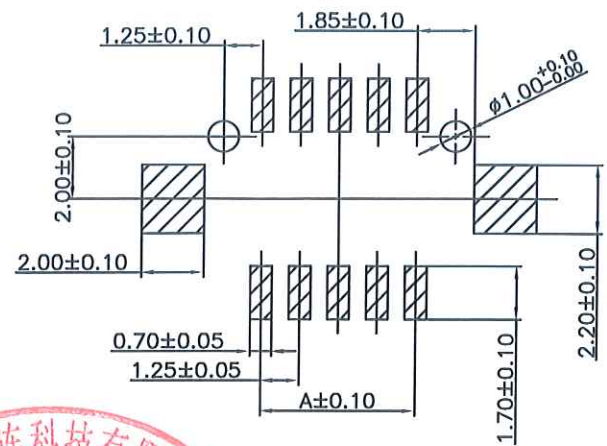
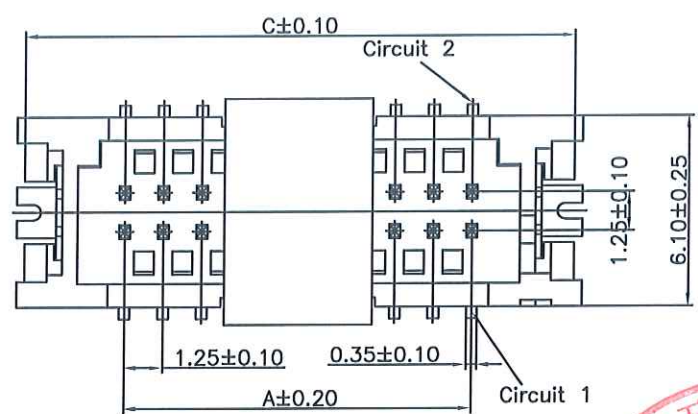

P.C.B LAYOUT

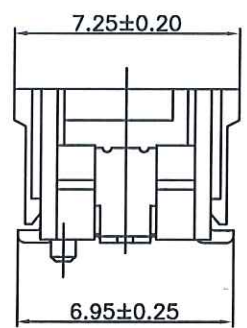
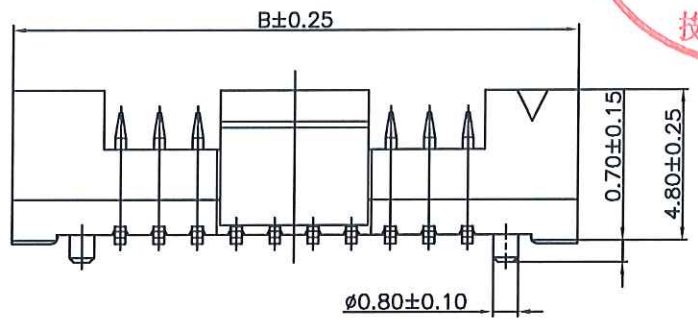

Ordering Information & Dimensions

Circuit	Dimensions(mm)		
	A	B	C
10	5.00	12.10	11.60
12	6.25	13.35	12.85
14	7.50	14.60	14.10
20	11.25	18.35	17.85
30	17.50	24.60	24.10
40	23.75	30.85	30.35

REV.	REVISION RECORD	DATE		GENERAL TOLERANCES		SCALE: 1:1	NAME	DATE	PART.NO:	DWG.NO:	
A0	NEW RELEASE	21.01.13		LINEAR	ANGLES	APPROVED			A1252W01-2XX2XX0	ENDE05	
A1	PART NUMBER RENEWAL	23.10.10	0.0±0.35	X°REF±6°	DESIGNER					WanLian Technology Co., Ltd	
A2	PA6T IS CHANGED TO PA9T		UNIT:mm 0.00±0.25	X'±3°	DRAWN			TITLE: 1.25mm PITCH 180°DUAL ROW WAFER	REV: A2		SHEET: 1/2

The product using material and processing must conform to the "WI-PZ-001"HSF technical standard control requirements

RoHS

2X05~2X07 Contacts

2X10~2X20 Contacts

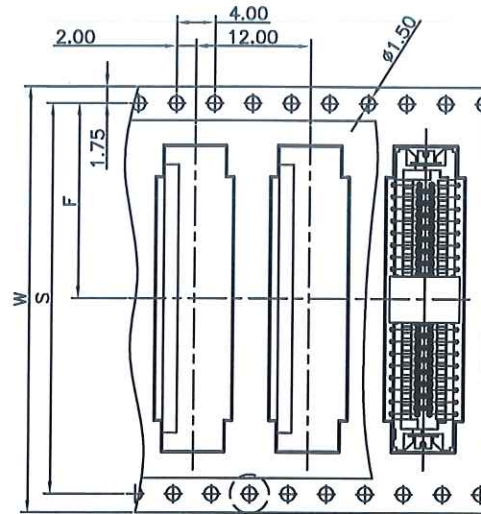
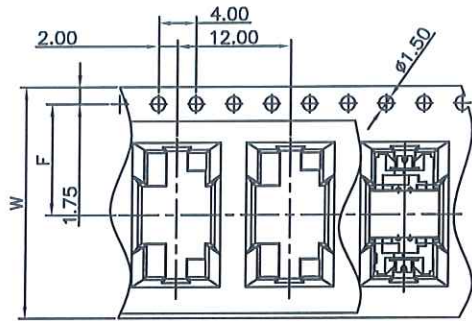

Unreeling direction

Unreeling direction

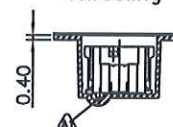
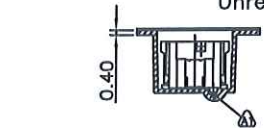

Carrier tape

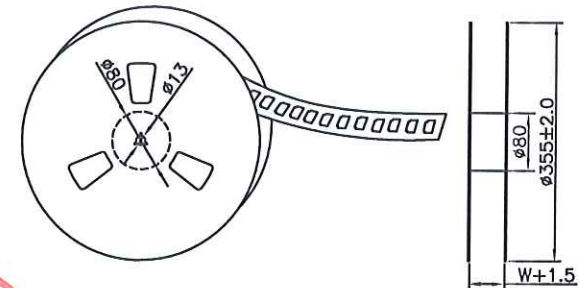
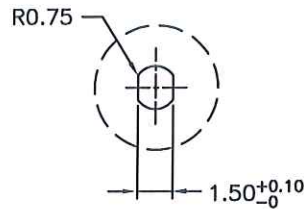

Number of Contacts	W±0.3	F±0.1	S±0.1	Q'ty/Reel
2X05P	24	11.50	/	1,000
2X06P	24	11.50		1,000
2X07P	24	11.50		1,000
2X10P	32	14.20	28.40	1,000
2X15P	44	20.20	40.40	1,000
2X20P	44	20.20	40.40	1,000



REV.	REVISION RECORD	DATE	GENERAL TOLERANCES		SCALE:	NAME	DATE	PART.NO:	DWG.NO:	 WanLian Technology Co., Ltd
A0	NEW RELEASE	21.01.13		LINEAR	1:1		25.4.17	A1252W01-2XX2XX0	ENDE05	
A1	PART NUMBER RENEWAL	23.10.10		0.0±0.35	ANGLES					
A1	PA6T IS CHANGED TO PA9T		UNIT:mm	0.00±0.25	X'REF±6'	DRAWN	25.09.17	TITLE:	1.25mm PITCH 180°DUAL ROW WAFER	
			SIZE: A4	0.000±0.10	X'X' ±2'			REV: A2	SHEET: 2/2	