

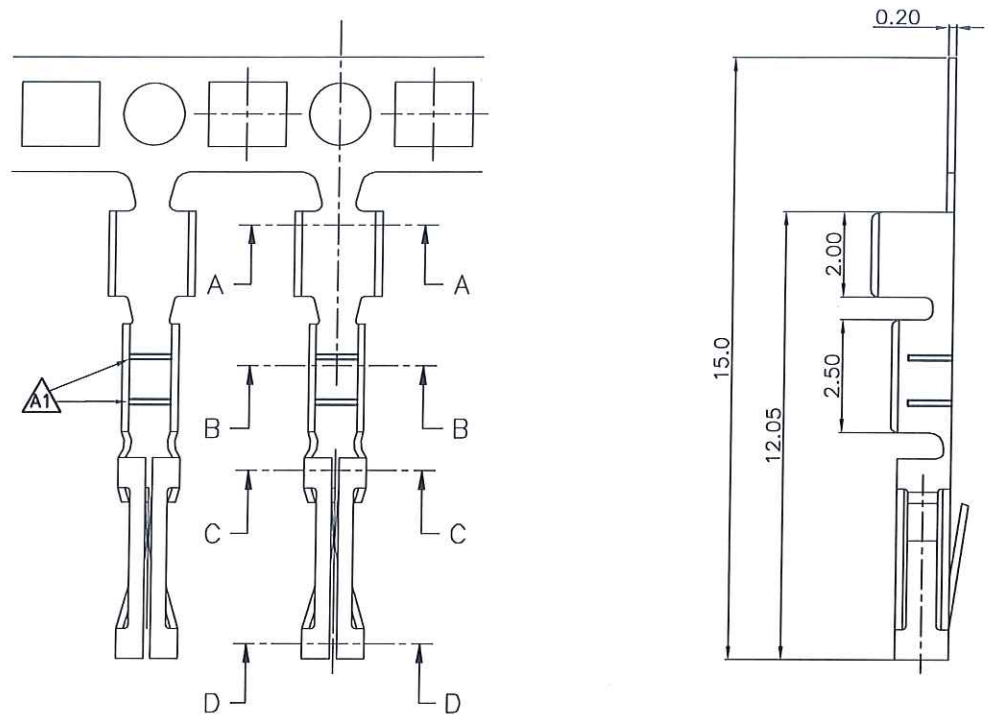

The product using material and processing must conform to the "WI-PZ-001"HSF technical standard control requirements



- NOTE:
- MATERIAL SPECIFICATION:
    - 1-1.TERMINAL: PHOSPHOR BRONZE
  - PLATING SPECIFICATION:
    - 2-1.TERMINAL: TIN/GOLD FLASH PLATED OVER ALL.
  - ELECTRICAL PERFORMANCE:
    - 3-1.CURRENT RATING: 3A AC/DC
    - 3-2.CONTACT RESISTANCE: 10 mΩ MAX
    - 3-3.INSULATION RESISTANCE: 100MΩ Min
    - 3-4.DIELECTRIC WITHSTANDING : 1500V
  - ENVIRONMENTAL PERFORMANCE:
    - 4-1.OPERATING TEMPERATURE: -25°C~+85°C.
  - PACKAGE SPEC: REEL
  - P/N:

SERIES NO: A2549 T 1 F X-X  
 CONNECTOR: T-TERMINAL  
 1-TYPE CODE  
 MALE FEMALE: F-FEMALE  
 PLATING:  
 1-G/F  
 C-BRIGHE TIN  
 D-MATTE TIN  
 METAL:  
 P-PHOSPHOR BRONZE

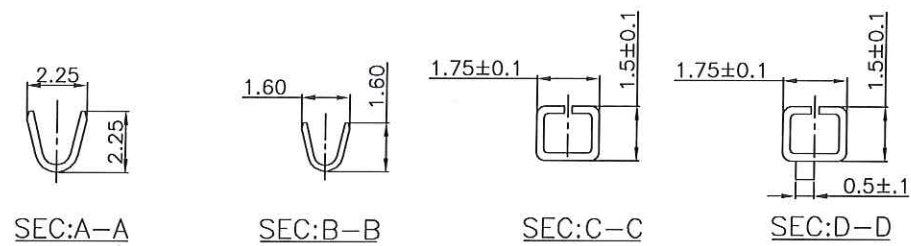

Ordering Information & Specifications

Wire Range	Insulation O.D.	Material	Finish	Qty/reel
AWG#22-#26	1.55mm(max)	Phosphor Bronze	Tin-plated	15,000pcs
AWG#22-#26	1.55mm(max)	Phosphor Bronze	Gold-flash	15,000pcs

REV.	REVISION RECORD	DATE	GENERAL TOLERANCES	SCALE:	NAME	DATE	PART.NO:	DWG.NO:
A0	NEW RELEASE	22.09.23	LINEAR	1:1			A2549T1FX-X	ENDE05
A1	MODIFIED IN KIND ON BASIS		0.0±0.35	APPROVED	2024.12.30			
			0.00±0.25	DESIGNER	2024.12.30		TITLE:	
			0.000±0.10	DRAWN	2024.12.30		Pitch 2.54mm TE 母端子 AWG#22~#26	

**W** 万连科技  
 WanLian Technology Co., Ltd  
 REV: A1 SHEET: 1/1