

The product using material and processing must conform to the "WI-PZ-001"HSF technical standard control requirements



RoHS

02P

03~06P

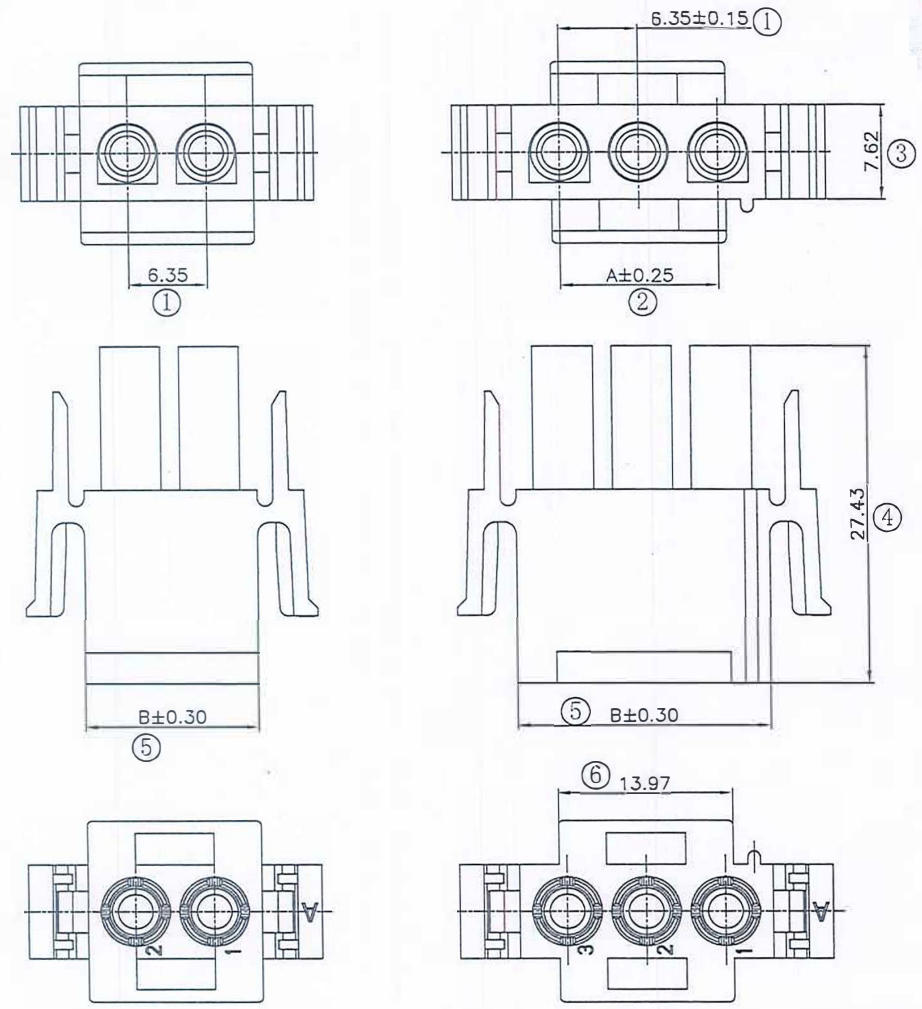

NOTE:  
 1.MATERIAL SPECIFICATION:  
 1-1.HOUSING: PA66;  
 2.ELECTRICAL PERFORMANCE:  
 2-1.CURRENT RATING: 15A  
 RATED VOLTAGE : 600V  
 2-2.CONTACT RESISTANCE: 3.5 mΩ MAX  
 2-3.INSULATION RESISTANCE: 1000MΩ Min  
 2-4.DIELECTRIC WITHSTANDING : 5000V AC  
 3.ENVIRONMENTAL PERFORMANCE:  
 3-1.OPERATING TEMPERATURE: -25°C~+85°C.  
 4.PACKAGE SPEC: PE BAG  
 5.P/N:

C6351 H 1 M-1 XX X X  
 SERIES NO: \_\_\_\_\_  
 CONNECTOR: \_\_\_\_\_  
 H-HOUSING  
 2-TYPE CODE:2- \_\_\_\_\_  
 MALE FEMALE: \_\_\_\_\_  
 M-MALE  
 F-FEMALE  
 ROW NO: \_\_\_\_\_  
 1-SINGLE ROW  
 HOUSING:  
 0-UL94V-0  
 2-UL94V-2  
 COLOR:  
 S-NATURE  
 PIN Q'PY:  
 02~06

Circuit No.	Dimensions	
	A	B
02P	6.35	13.97
03P	12.70	20.32
04P	19.05	26.67
05P	25.40	33.02
06P	31.75	39.37

REV.	REVISION RECORD	DATE	GENERAL TOLERANCES		SCALE:	NAME	DATE	PART.NO:	DWG.NO:
AO	NEW RELEASE	22.03.19	LINEAR	ANGLES	1:1	Wang_jr	22.03.19	C6351H1M-1XXXX	ENDE05
			0.0±0.35	X'REF±6°	APPROVED	XueZe_Ma	22.03.19	TITLE: Pitch 6.35mm 单排公壳	REV: AO SHEET: 1/1
			0.00±0.25	X'±3°	CHECK	LanXuan_Hou	22.03.19		
			0.000±0.10	X'X' ±2°	DRAWN				

